

Sine wave generation using the amplitude modulation logic of the DDS carrier board

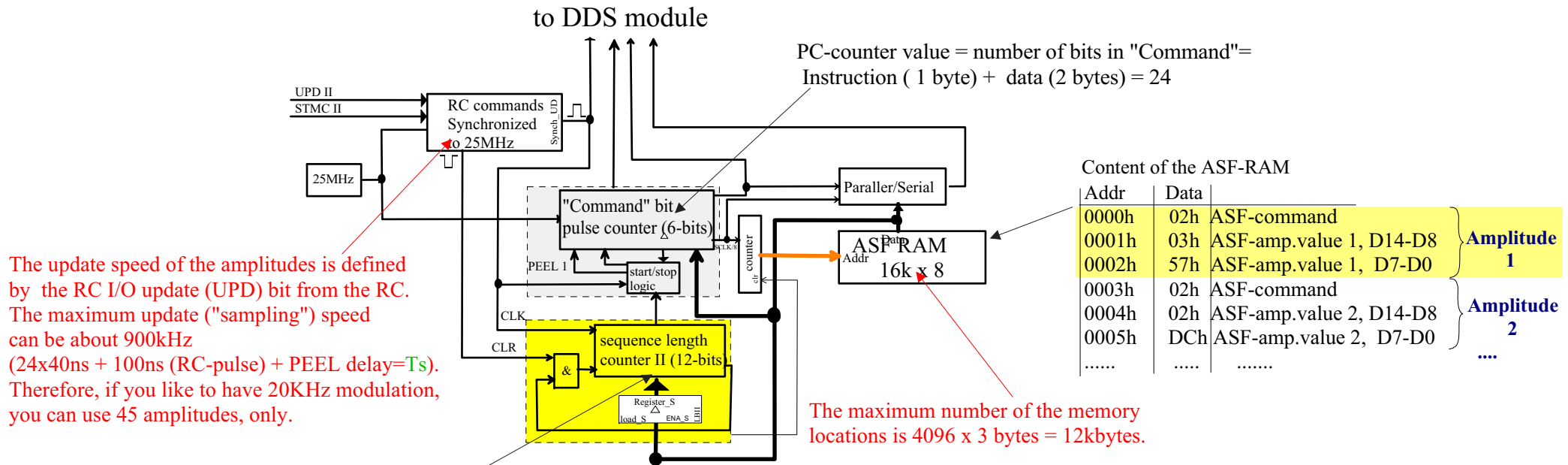

SC-counter value = number of bytes in "Command" x number of amplitudes (samples = Tmod)

