

1981 - 2011

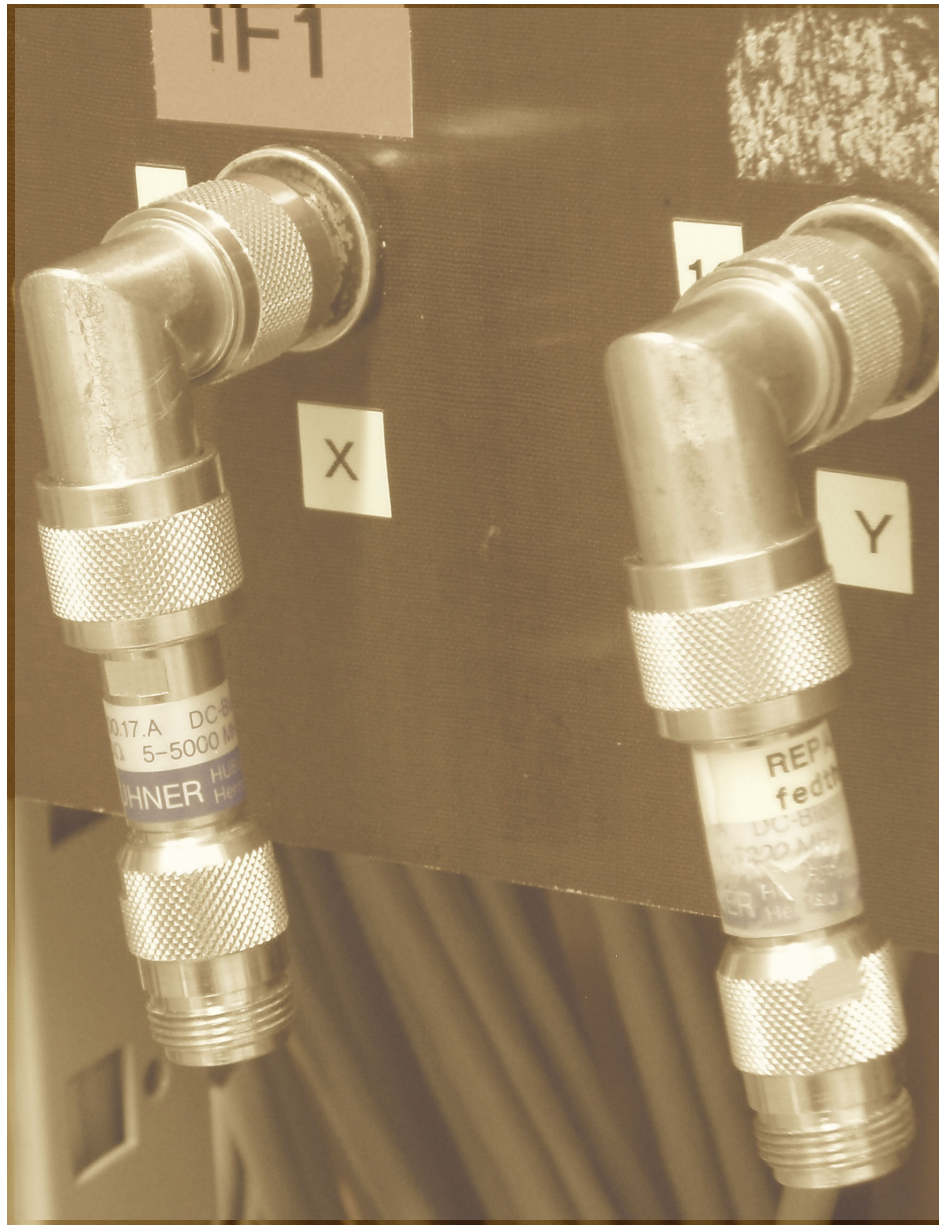

Jussi I Markkanen

End of UHF Measurements at the EISCAT Sodankylä Site

February 2012

Contents

1	To the end	3
2	The site's frequency protection	6
3	Effects of the interference	8
4	Summary	12

List of Figures

1	Summary.	13
2	RTGRAPH displays of BEATA in 2009–2011	14
3	RTGRAPH display of BEATA on 27 Nov 2011	15
4	IF1 spectrum in Mar 2009, Aug 2010 and Nov 2011	16
5	GSM channels in the SOD GSM band	17
6	EISCAT UHF frequencies	18
7	Block diagram of the Sodankylä receiver	19
8	The last echo	20
9	Sodankylä site radio sky 27 Sep 2010.	21
10	Sodankylä site radio sky 21 Mar 2011	22
11	Sodankylä site radio sky 17 Sep 2011	23
12	Sodankylä site low-elevation radio sky Sep 2010 and Mar 2011	24
13	Sodankylä site low-elevation radio sky 17 Sep 2011	25
14	Azimuth scan in Jan 2012 v. Sep 2011	26
15	Direction map of strong interference	27
16	3G coverage of the three nationwide operators	28
17	Coverage of DNA mobile services in Sodankylä in Dec 2011	28
18	IF2 output voltage v. attenuator setting	29
19	IF2 spectrum v. attenuator setting	30
20	BEATA in CP1 direction when enough attenuation is used	31
21	BEATA in a relatively quiet direction with enough attenuation	32
22	IF2 spectrum in two pointing directions	33
23	IF1 v. RF when GSM filter is not used	34
24	IF1 v. RF at waveguide output	35
25	IF1 v. RF at IF1 input	36
26	IF1 with and without the GSM filter	37
27	IF2 v. IF1	38

1 To the end

In the early afternoon on Sunday 27 November 2011, after a scintillation measurement campaign in October, Toivo Iinatti and myself changed the Sodankylä receiver from 1.4 GHz back to the normal 930 MHz configuration, in preparation for a CP experiment due the following week. Later in the evening I started the standard UHF single-frequency experiment BEATA to find out the system temperature via the RTGRAPH program, as we usually do.

The expectation was to find a system temperature around 50 K and a display looking similar to the one shown in Fig.2, containing maybe some occasional interference, but still predominantly clean data. Instead, the screen display was like the middle panel of Fig.3, showing no noise injection and a crazy background spectrum. Trying BEATA on all the six EISCAT frequencies F11-F16 (929.3–930.8 MHz) that fit into the Sodankylä receiver's 1.5 MHz passband, which I will call the SOD GSM band in this report, showed that all of the site's frequency channels were more or less similarly damaged.

When the spectrum analyser was connected to the first intermediate frequency (IF) of the receiver (see Fig.6 for the frequency mappings in the receiver and Fig.7 for the receiver block diagram), a picture emerged that was drastically different from what we had got used to during the last few years. Figure 4(a) shows the IF1 spectrum photographed from the spectrum analyser display, and, photoshopped on top of it, a spectrum taken with similar analyser settings a little more than a year earlier. We had become accustomed to seeing GSM signals on both sides of the SOD GSM band (Fig.4(b) is a very tame example), but now there were tens of decibels of new unwanted signals directly and firmly within the band. It was obvious that what we had been dreading ever since the site had lost its frequency protection in summer 2010, a GSM base station had started transmitting directly into the band from a location near the site.

In order to monitor the interference situation, I had been making occasional maps of Sodankylä UHF sky since late summer 2010, and those had shown a slowly worsening environment, as illustrated in Fig. 9–13. In August 2010, only the frequency F13 (929.9 MHz) was suffering from severe corruption, and even that only in directions on the sky that are not used in standard experiments. On F13, the strongest disturbance was coming from azimuth about 147°. As shown in the map Fig.15, that direction crosses the mountain Pyhätunturi some 45 kilometres from the site. On Pyhätunturi there is a major radio mast, directly visible from the site. The EISCAT pointing geometry program places the Pyhätunturi mast to azimuth 146.0 and distance 45.8 km from the Sodankylä site. The mast probably was the source of the interference at F13.

As the interference level kept increasing in 2010, EISCAT looked for a frequency which would give as low a system temperature as possible in Sodankylä and in late 2010 started using F14 as the main transmission frequency for remote reception in tristatic experiments. Earlier, F12 had been used.

In March 2011 the sky map (Fig.10) showed increased interference in the high-frequency end of the SOD GSM-band so that F16 (930.8 MHz) had become unusable. As F16 is not used for transmission anyway, this was no big loss. The worrying thing was that for the first time the interference was spread all over the sky, as the F16-panel in Fig.10 shows. The strongest source (Fig.13(d)) appeared to be what we now know to be a GSM base station mast used by the mobile operator DNA. The mast is in the Sodankylä village, about six kilometres from the site at about azimuth 334°. The F16 interference probably was our first clear sign that DNA's UMTS channel (Fig.5, Fig.23)

was being activated in the Sodankylä village, although we did not understand the message then.¹

Data for the next, and last, of the all-sky maps (Fig.11 and Fig.13) was measured on 17 September 2011. To my considerable chagrin, I only analysed the September data in November, after being brought from hibernation by the 27 November shock, and so failed to notice at the time that we had completely lost the lowest frequency in the SOD GSM band, F11 (929.3 MHz). On F11, the whole sky was strongly corrupted, without any low-noise spots. Consistently with this, in the low-elevation azimuth scan shown in the top panel of Fig.13(c), the whole background has been almost uniformly raised by more than 10 dB in all azimuths, compared to the other frequencies.

I do not understand how such a uniform increase, at one frequency but not the others, can come about, for the receiver would still presumably to be operating linearly. In general, the distribution of the interference in the all-sky maps clearly is not random. There are at least two distinct patterns. One pattern consists of more or less smooth arcs and rays spreading from, or centred at, on a point-like source near the horizon, the radio mast. The interference at F13 is of this type. The interference at F16 also has the arc structure, but in addition, there are horizontal stripes that extend through most azimuth angles, showing little or no respect to the antenna gain pattern.

I have no good explanation for the interference patterns. I could imagine that the smooth arcs come about via some kind of scattering, even multiple scattering, from the subreflector and its support beams—which have a roundish cross-section—but anyway from the direction where the mirror is facing. Regarding the horizontally layered, sky-filling interference pattern, Fig.13(b) and Fig.13(d) indicate rapid intensity variations as function of azimuth. This suggests scattering from sharp edges in some structures of the antenna, like the crisscross of steel beams that supports the main mirror and forms the bulk of the antenna body. Some of the I-shaped beams have a diameter that is roughly comparable to the radar wavelength, which could make them good scatterers. Coincidence or not, in the F11-panel of Fig.11 there is global *minimum* in the sky-filling interference in the azimuth direction of the source, the direction where the support structures are most completely in the shadow of the mirror. On the other hand, in Fig.13(c) the rapid intensity variations are not manifest.

The sky map on 17 September 2011 is the last in the series. After the discovery in 27 November it has become clear that there is little point in using effort and electricity for any more 11-hour mapping runs. We also learned from a contact in the industry that DNA had finally started making use of their frequency allocations in Sodankylä and had started 3G transmission from a base-station in Sodankylä village about a week earlier.

Figure 17 shows the coverage map of DNA 2G and 3G services near Sodankylä village. I have marked to the map the location of the EISCAT antenna and the location of a radio mast in the suburb Emmaus of Sodankylä. According to the DNA web page the map was updated in 12 December 2011, which is suggestive. The map shows 3G coverage snaking down along the river Kitinen towards the EISCAT site. There is a white spot in the coverage map just on top of the site, though. The Emmaus mast is at azimuth 333.8 degrees, at the range of 6.08 km, according to the EISCAT pointing geome-

¹If Tarmo Laakso, a long-serving staff member who had been carefully following the interference situation since the early NMT days, had not been recently pensioned, undoubtedly an alarm would have been raised. The end would hardly have been any different, but its coming would have been monitored more closely.

try program.² Maybe we could make use of these masts for pointing calibration at low elevations. They anyway are becoming more numerous than suitable celestial radio sources (Fig.15).

I have made some cursory mapping of the new interference by slewing the antenna slowly under manual control and estimating the received power from a spectrum analyser display on the IF1 level. It is best to use IF1, for even with the interference, IF1 still behaves decently; it is mainly the IF2 unit and the digital receiver that don't cope well with the increased load, as is described in Chapter 3. The strongest disturbance in the NE sector towards Tromsø comes from the Emmaus mast. Figure 14 compares a low-elevation azimuth scan from September 2011 to a manual measurement done in mid-January 2012. Both measurements refer to F13, which is now by far the least disturbed frequency in the SOD GSM band. The Emmaus source is visible in all the previous sky maps as well, but is now much stronger than in the previous measurements. Perhaps earlier the mast has been transmitting mostly outside the SOD GSM band.

On that Sunday afternoon in November, after having observed RTGRAPH reporting a NaN for the system temperature, for a short moment one could still hope that it was just the noise injection itself that was somehow broken. But from the first glance at the spectrum analyser display with the huge in-band interference, it was clear that with or without the injection, this was a show-stopper.

As luck would have it, the Finnish representative to the EISCAT Council, together with the Finnish SOC member, had come visiting the site at the very moment when I was beginning work with the spectrum analyser. I had the good opportunity to inform them first-hand and in a satisfactorily timely manner about the demise of thirty years of tristatic EISCAT UHF measurements. They appeared politely interested.

Inspecting afterwards the site's recorded data, it appears that the last data dump containing an ionospheric echo was taken on 11 August 2011 at 22:00:00 UT, when August's long BEATA experiment was stopped on schedule by an EROS command from Tromsø. RTGRAPH picture of that dump is shown in Fig.8(a). The next dump at 22:00:05 in Fig.8(b) shows some disturbance and no echo; whether the disturbance is related to the down-going transmission or up-going interference I don't know.

At 22:00:25, Fig.8(c), the transmitter's power-down cycle had been completed in Tromsø and the Sodankylä system temperature had settled back to the normal 50 K. That was the end. As far as I know, there were no kings nearby.

²I computed the azimuth and range by picking the mast's geographic position in the ETRS89 coordinate system from the on-line service of the National Land Survey (NLS) of Finland, and using the latitude and longitude in the EISCAT pointing geometry program. It was a nasty surprise when the program gave a result that was more than a hundred meters in range and about two degrees in azimuth off from the values I had initially estimated from a paper map. When I fed the official Sodankylä antenna coordinates to the NLS service, the service drew an arrow that pointed robustly into the river Kiinen about 150 m towards west and slightly towards the north from the actual antenna location on the map. This was not good. Especially when I recalled that during my space debris work, ESA experts when analysing our satellite orbit measurements had suggested that EISCAT antennas might not be precisely where our documentation claims them to be. The axis sizes of the GRS80 spheroid, which underlies the ETRS89 coordinate system, differ only by about two meters from the spheroid that EISCAT pointing geometry uses, so the spheroid probably is not the issue. Perhaps the official site coordinates refer to some different geographic position system. I changed the geometry program—temporarily—to use the antenna coordinates I had got from the NLS service, and then the geometry program and the manual measurement agreed very well.

2 The site's frequency protection

The Sodankylä site has never had a long-term frequency protection. Ever since the appearance of the NMT-system (Nordic Mobile Telephony) in the early 1980s into Scandinavia, conflict of interest between EISCAT and the mobile service providers has been a growing concern. The NMT900 system, whose base stations are specified to the 935–960 MHz frequency range, started operating in 1987–88 in Finland. After initial problems for EISCAT, effects of the NMT900 interference to the UHF system were successfully mitigated by hardening the receiver front-end and slightly down-shifting UHF transmission frequencies. The evasion was possible as the Finnish telecom regulator, then the Telecommunication Administrative Centre (Telehallintokeskus, THK), agreed to restrict the use of NMT base station frequencies in northern Finland so that guard zones were left at and around the EISCAT UHF frequencies, within 100 km distance from the site. In Sweden corresponding measures were taken.

When NMT900 was finally switched off twenty years later in 2007, the second generation of mobile communications in the form of the GSM900 system, had been up and running for more than ten years. It uses roughly the same frequency region as NMT900, but has longer range and wider (200 kHz instead of 15 kHz) channels than NMT, and therefore poses even more severe problem for EISCAT UHF.

For a perhaps surprisingly long time, the Nordic telecom authorities, in Finland first THK and since 2001 Ficora (Finnish Communications Regulatory Authority), managed to maintain a most helpful view about EISCAT's needs.³

Based on a meeting in the spring 2001 between the regulator, the concerned mobile operators, and EISCAT (which was represented by Tauno Turunen), the regulator decreed that within a circle of 50 km radius from the site, the frequencies 927.6–928.8 MHz [sic.] were not allowed. That is what the THK document 14857, a letter to Finnish 2G, says. The mentioned frequency interval is not precisely what I have been calling the SOD GSM band here, the interval 929.2–930.8 MHz. I have not been able to trace down when and how the zone was shifted upwards.

By 2005 EISCAT had got a small, but explicit, place in Ficora's radio frequency order, which is the definitive statement about the use of radio frequencies in Finland. For the frequency range which includes EISCAT UHF, the following note can be read.

Ficora Order 4F/2005 M on 8 March 2005 [...] 925.2–959.8 MHz [...] there are] special arrangements concerning the frequencies allocated to Finnish 2G Ltd in Sodankylä within 100 km distance from the EISCAT-research station.

The Finnish 2G is what nowadays is called the DNA Networks Ltd.

In 2007 a GSM-protection zone of 100 km radius around the Sodankylä site was for the first time established on the government level, via the Decree 680/2007. Paragraph 5 of the decree concerns second generation mobile communications networks.

³I assume that at times catering for science's interest has been awkward. Imagine being the CEO of a big national service provider who is shown a coverage map like the one in Fig. 17 where in your data, and your data only, there is a pretty conspicuous 200 km wide no-go circle, covering most of Lapland and centred at—what!—an obscure tiny research station no one has ever heard anything about. Wouldn't you be tempted to pick up the phone for some serious chat with the regulator? Me, too. But what actually rather happened, back in 2007 before the coverage map had got quite to the density shown, was that one of the other operators requested that the regulator postpone 3G's introduction to Lapland by several years for all operators, essentially on the basis that they themselves were not interested in expanding 3G to Lapland at that time, and did not want competitors to go there either. The regulator decided to kick-start an expansion nevertheless. For Lapland, that probably was the correct act.

Government Decree 680/2007 on 14 June 2007, § 5 . [...] The frequencies 928.9–930.5 MHz (GSM radio channels 994–1001) must not be used for mobile communications within the distance of 100 km and the frequencies 927.5–928.9 MHz (GSM radio channels 987–993) and 930.5–931.9 MHz (GSM radio channels 1002–1008) within the distance of 50 km from the EISCAT radio receiving station (26E3818 67N2145) in Sodankylä, unless the regulatory authority, based on Act 1015/2001 [...], paragraph 8, first subsection, does not otherwise order in the conditions for the [mobile operator’s] radio permission.

Not surprisingly, Ficora’s radio frequency order 4L/2008, dated 19 December 2008, pays explicit respect to the Decree 680/2007 by repeating verbatim the decree’s EISCAT restriction when stipulating the use of the 925.2–959.8 MHz band. But then, in the radio frequency order 4L/2009 on 4 November 2009, the regulator yielded to the commercial pressure. The order first stipulates, in the same words as previously, the existence of the Sodankylä GSM protection zone, but then declares that the protection will end on 30 June 2010.

Ficora Order 4L/2009 M on 4 November 2009 [...] The [EISCAT restriction] is valid until 30 June 2010.

In the second half of the first decade of the millennium, the commercial competition in providing 3G (that is, UMTS-based) mobile communications services in Finland was intensifying between the three national service providers TeliaSonera, Elisa and DNA. One UMTS channel requires about 5 MHz bandwidth, which corresponds to about 25 of the 200 kHz wide GSM channels, in a continuous block. The problem was that TeliaSonera and Elisa possessed GSM900 frequencies in wide enough continuous block to immediately allow them to start providing also nationwide UMTS900-services, but due to the EISCAT-protection, DNA did not. DNA had its GSM frequencies in two blocks: 19 so-called P-GSM frequencies, all well above the EISCAT UHF band, and 35 so called E-GSM frequencies. But out of the latter, DNA could not use 22 in Lapland, because of the EISCAT frequency protection. Thus, DNA could not form any 5 MHz UMTS channel in Lapland. In fact, with the EISCAT protection in place, there was no way for Ficora to reshuffle the available frequencies so that all three operators would get a nation-wide UMTS channel. Ficora seems to have decided that this state of affairs was unfair towards DNA and would distort competition. EISCAT had to go.

Much as an EISCAT person might regret Ficora’s decision, a mobile-dependent Finnish consumer will see the need for operator competition, and acknowledges that fairness is an important criterion. Ficora’s reasoning is explained in their document from 31 October 2007 about the frequency allocation. The document 958/700/2007⁴, “Radio permission decision concerning the usage rights of the 900 MHz frequencies allocated for mobile communications in mainland Finland from 1 November 2007 onwards”, is addressed to the three nation-wide service providers.

The starting point of the Ficora decision is the government Decree 680/2007, the same one that provided the EISCAT protection zone in its paragraph 5. Namely, the decree also provides, in its paragraph 6 which concerns 3G networks, an unalienable right to UMTS for any qualified operator, such as DNA.

Government Decree 680/2007, § 6 A teleoperator which has the right to GSM mobile operations on frequencies [...] 925–960 MHz [...] can use these frequencies in the same extend

⁴The document was available as www.ficora.fi/attachments/suomiry/5t7vt8yvR/Paat071031dna.pdf

also for UMTS mobile communications.

Ficora acknowledges that it must consider the following items (among others):

1. DNA's right to UMTS is backed by the the law in a very direct way.
2. A regulator is required by the law to provide equal opportunity for all qualifying applicants.
3. EISCAT protection prevents Ficora from allocating frequencies so that (2) can be fulfilled with regard to (1).
4. But also EISCAT is protected by the same law, and Ficora explicitly says that it interprets the Decree 680/2007 so that the regular can issue additional qualifications about how the EISCAT protection must be done, but it cannot by its own decision completely repel or remove the protection granted by the decree.

This looks like a conflict. To solve it in a way that caters for the overarching requirement of fair commercial competition for the benefit of consumers, Ficora suggested that the decree must be amended with respect to EISCAT. The following is what the decision 958/700/2007 says about EISCAT and its frequency protection.

[...]In Finland the use of frequencies for EISCAT research is protected by the government Decree 680/2007 §5. In EU 6th framework programme a work is currently going on to find a technical solution that would allow EISCAT activity to be moved over to another frequency region.

The regulator has on 20 September 2007 made to the communications ministry a request to prepare a change to the Decree 680/2007 in such a way that the protection of EISCAT research would be removed after a suitable transition period.

The regulator has correspondingly informed parties representing the EISCAT organisation that all 900 MHz frequencies will in the future be needed for their primary use, that is, mobile communications. EISCAT organisation has been asked to prepare for this and apply for another frequency for the research purposes.

The Decree 680/2007 was repealed by the Decree 1169/2009 dated on 22 December 2009 and valid from 1 January 2010. It reaffirmed the § 5 in its earlier form. Ficora's request 20 September 2007 to the ministry was implemented simply by stating that the second subsection of § 5, which concerns the EISCAT-protection, will expire on 30 June 2010.

Accordingly, the Ficora radio frequency order 4L/2009 set the end of EISCAT frequency protection to the end of June 2010. After 2009, subsequent radio frequency orders no more make any mention of EISCAT-protection at all.

3 Effects of the interference

In the EISCAT Annual Review Meeting in February 1988, in his talk about the NMT interference Gudmund Wannberg warned about the possibility of "serious overload and intermodulation problems in existing EISCAT receivers, even if the base frequencies are located outside of the primary EISCAT band", and reported that "recently, a new base station was opened so close to the Sodankylä site that the field strength received from it is large enough to drive even the first mixer to nonlinearity".

Subsequently, a new first mixer was designed and taken in use with “ten times more resistant against strong signal overload than the present one”. Also, new filters were ordered, and frequencies were shifted, and these actions have allowed EISCAT UHF to operate in Sodankylä, until now.

Preamplifier

After the 1988, also the preamplifiers have been improved, and it seems that even with the newest interference, the receiver front end can more or less handle the signal levels. When Lars-Göran Vanhainen (LGV) from the Kiruna site was visiting Sodankylä in December to inspect the interference, we tested the preamplifier by transmitting a variable strength sinusoidal signal at 930 MHz from a signal generator in the site building into the EISCAT antenna, and measuring the signal strength with spectrum analyser after the preamplifier. It appeared that the preamplifier was still operating linearly. In the test, the antenna was pointed to AZ 310°, EL 3°, about 24 degrees off from the most seriously offending GSM-transmitter (see Fig.14). In this direction, the most prominent GSM-signal is some 7 dB stronger than in the CP1-direction, according to Figures 24(b) and 27(a). More generally, Fig.24 suggests that the whole receiver section from waveguide up to and including the first IF unit behaves linearly, provided that the GSM filter is used. The conclusion is that

- The preamplifier is able to cope with the increased interference, at least in the most relevant pointing directions.

First IF unit

During LGV’s visit, we took also a few readings of the test-transmitter signal after the first IF unit, down in the receiver hall. These measurement also seemed to indicate linearity between antenna and IF2. Subsequently, I have inspected the situation more closely by comparing spectra taken at various parts in the signal path, both on the X-path which has the GSM filter in place, between the two preamplifier stages (Fig.7), and on the Y-path, where we now do not have the GSM filter⁵. The first conclusion is that

- It is absolutely necessary to use the GSM filter.

Figures 23 and 26 show that without the GSM filter, at least 20–30 dB of unwanted signals get mixed to the EISCAT GSM band. The net effect is that the noise floor is raised dramatically on the GSM pass-band when the GSM filter is removed. We surely do not want to dump 20—30 dB of extra noise on top of the only even remotely usable frequency, F13. This is not how a linear system behaves, but what is the distortion mechanism in this case, I don’t know. In particular, this does not look similar to the third-order intermodulation distortion that ruins IF2 (see below). It is more like wide-band noise mixing into the IF1 band. This could happen in the IF1 mixer or in the IF1 amplifier. I vaguely suspect the latter, mainly because in Fig.23 the out-of-IF1-band noise floor does not appear to drop as fast as it should if the IF1 filter were active, and it is the amplifier rather the mixer that is after the filter in the signal path.

⁵LGV took that filter with him to Kiruna for testing possibilities for re-tuning it. I now think that those tests will be irrelevant. The GSM filter will not be able to save the day.

On the other hand, when the GSM filter is used as it normally is, the IF1 unit seems to be able to translate the contents of the SOD GSM band without distortions from RF to IF1. This is shown in Fig.24 for the whole section from waveguide output to IF2 input and, in Fig.25 just across the IF1 unit.

- With the GSM filter in place, the IF1 unit behaves linearly even with 50–70 dB of new in-band interference.

Kudos to the people who designed and implemented the new IF1 system in connection of the NMT interference and afterwards.

Second IF unit

After the first bandpass filter in the IF2 unit (Fig.7), there is a computer-controlled attenuator, termed the signal attenuator. It can be set between 0 and 63 dB in one decibel steps. For several years, the default value of the signal attenuator in Sodankylä has been 4 dB. With the new in-band interference, this value is entirely insufficient. Figures 18 and 19 show that, for instance, in the CP1 direction some 15–20 dB more attenuation is required before the IF2 unit starts to behave at least roughly linearly. Before at least that level of attenuation is set, a text-book case of third-order intermodulation distortion becomes visible.

In this distortion, the IF2 amplifier behaves like a mixer and generates strong harmonics. In particular, the dominant in-band GSM channel 996 (and 995 and 997 on its sides) at about IF2 frequency $f_1 = 10.5$ MHz has its second harmonic $2f_1$ at 21 MHz. This harmonic then mixes in the amplifier with other parts f_2 of the IF2 spectrum. The sum frequencies $2f_1 + f_2$ go way out of the GSM band for all f_2 in the band, but the difference $2f_1 - f_2$ can fall in the band. In particular, the relatively strong UMTS channel at IF2 frequencies $f_2 \lesssim 9.5$ MHz mirrors across f_1 to the top of frequencies $f_2' \gtrsim 11.5 = 21 - 9.5$ MHz. This behaviour becomes very conspicuous by comparing panels (a) and (d) of Fig.19. The distortion does not spare the frequency F13 at 10.1 MHz either. There is considerable power at, and especially around, the frequency 10.9 MHz also, which can be mixed to 10.1 MHz by a suitable part of the several hundred kHz wide GSM peak. Even a *small* amount of this distortion can seriously contaminate F13. In Fig.19, the level at F13 still goes down with respect to filter noise level when attenuator is changed from 25 to 30 dB.

- To avoid third order intermodulation distortion corrupting (also) F13, a high signal attenuation setting, at least some 30 dB in the CP1 direction, must be used.

A/D converter

But even more attenuation is required. The purpose of the IF2 unit is to condition the analogue signal suitable for A/D conversion. In the present EISCAT receiver, the conversion is done before division to narrow baseband channels, on the IF2 level. The A/D converter requires a peak-to-peak voltage within ± 1 V. The converter clips, quite sharply and without setting any flags, everything outside this voltage range. Heavy clipping affects both the perceived system noise temperature and spectral shapes, and is the immediate reason why the RTGRAPH display on 27 November went crazy like

shown in Fig.3. Overvoltage cannot be tolerated, and the purpose of the signal attenuator has been to keep the typical, system noise-dominated voltage level in the low hundreds of millivolts.

Inspecting the IF2 voltage with a scope, it turned out that e.g. in the CP1 direction, 35 dB of signal attenuation was required to bring the voltage within the ± 1 V range (Fig.20). This is somewhat, but not much, higher than what is already required to guarantee linearity of the IF2 unit.

- To avoid A/D converter from clipping, a high signal attenuation setting, at least some 35 dB in the CP1 pointing direction, must be used.

Digital receiver

Differently from the present receiver, in the original EISCAT receiver the A/D conversion was done after analog detection to baseband. With that kind of system, we could now tune a hardware channel to F13, complex-multiply (demodulate) to baseband in the analogue domain, then use a good 100 kHz analogue low pass filter as the post-detection filter, and only then do the sampling. The filter would probably still see at least part of the adjacent GSM channels, so rather a lot of attenuation might be needed in front of the A/D converter, and therefore maybe the converter should have a rather good bit resolution, say about 18-bits. The advance would be that the sampling rate would need to be only on the order of a few hundred kilohertz at most, and nowadays one can get even 20-bit A/D converters for a such sampling rates cheaply. With the old system as with the current one, enough signal attenuation would be required to ensure that IF2 system stays linear.

It seems impossible to handle the interference with the present receiver configuration, or with any simple change to it. The present A/D converter has 14-bit resolution, so 1-bit level is $20 * \log(2^{13}) = 78$ dB down from the maximum value. In the BEATA experiment, a little experimentation showed that to avoid excessive quantisation noise, at least 4–5 bits has to be kept active in the F13 data. This means that the effective available dynamic range is about $20 * \log(2^8) = 48$ dB. But the GSM interference signal adjacent to F13 is some 65 dB stronger than the noise level at F13 (and a typical radar echo will not improve that level much), so about 15 dB more dynamic range is required than seems to be available. With 6 dB of dynamic range per A/D bit, that means at least three more bits, that is, one would need at least an 18-bit converter. There does not seem to be an abundance of 18-bit A/D converter for 15 MHz sampling rate. And even if one could find one, the rest of the current digital receiver could not handle the word length and would need to be updated also. I suspect that the probability for such an update is very low.

- The present digital receiver does not have enough bit resolution to handle the required dynamic range, and cannot be easily updated either.

It might be possible instead to use a separate high-throughput-rate, on-the-shelf, digital receiver, such as the USRP receiver module which has been planned for EISCAT_3D. The idea would be to increase the receiver's effective dynamic range via aggressive oversampling followed by decimation done in floating-point on a computer. Such an approach has recently been successfully used by Andrew Senior and Juha Vierinen at EISCAT Heating, but whether it could significantly help with the GSM interference problem is an open question.

- A USRP-based oversampling receiver might, or might not, help at F13.

At the moment, there are still pointing directions where I think we would be able to detect an echo at F13 with the present system, just by using enough signal attenuation. And it might not be entirely impossible to get some kind of signal even in the standard CP1 direction, via improvements similar to those mentioned above.

However, work into this direction, even if successful, could easily become a wasted effort. The GSM channels at 929.8 MHz and 930.0 MHz immediately adjacent to F13 apparently are not used by the GSM stations closest to the site. But these channels are allocated to DNA, and indeed are already used somewhere further away from the site, for we can see them clearly in some pointing directions. With the site's protection gone, and demand for mobile services increasing, these channels can come to a mast near the site at any time. Surely nothing can save the day when there is a few tens of decibels of GSM transmission riding straight on top of the IS spectrum.

- Also F13 can become overloaded at any moment and without any warning.

4 Summary

After the site lost its frequency protection zone in summer 2010, GSM interference has been slowly nibbling away the edges of the SOD GSM band. Sometime in November 2011, permanent transmission started in the middle of the band from a mast 6.1 km from the site. This increased spectral power density by up to 70 dB on some frequencies in important directions. It appears that the receiver preamplifier and the first IF unit can cope even with this interference level without loss of linearity. However, the IF2 unit has not been designed to handle the load and saturates when normal level of attenuation is used. Hardening the IF2 unit does not help per se, for the real bottleneck is insufficient dynamic range in the A/D converter and the digital receiver.

At the moment, out of the GSM band frequencies F11–F15, F13 is still relatively undisturbed in the most important directions. But when enough attenuation is used to keep the IF2 unit linear and its output suitable for the A/D converter, too little active bits are left in the F13 data to make measurements possible. A solution would be to get an A/D converter and digital receiver with significantly higher bit resolution than the present 14 bits, so that some 100–110 dB of dynamic range would be available. That would basically mean a whole new digital receiver. Another way would be to increase the dynamic range by heavy oversampling, but that requires throughput rates not available in the standard receiver, either. Even if enough dynamic range could be achieved, there is no guarantee that the F13 slot would not become under strong interference, too. Figure 1 on the next page gives a pictorial summary of the situation.

At the site the inputs to the IF2 unit have been disconnected to prevent accidentally overloading the IF2 unit and the A/D converter. As of February 2012, all the parts of the receiver are still in normal working order. It would be good to keep them that way in wait for a possible "VHF-conversion" later in 2012. No one should attempt to use the Sodankylä system over the internet at present, but users are welcome to the site in person to challenge the main conclusion of this report, which is the following:

- Sodankylä UHF measurements have finished for good.

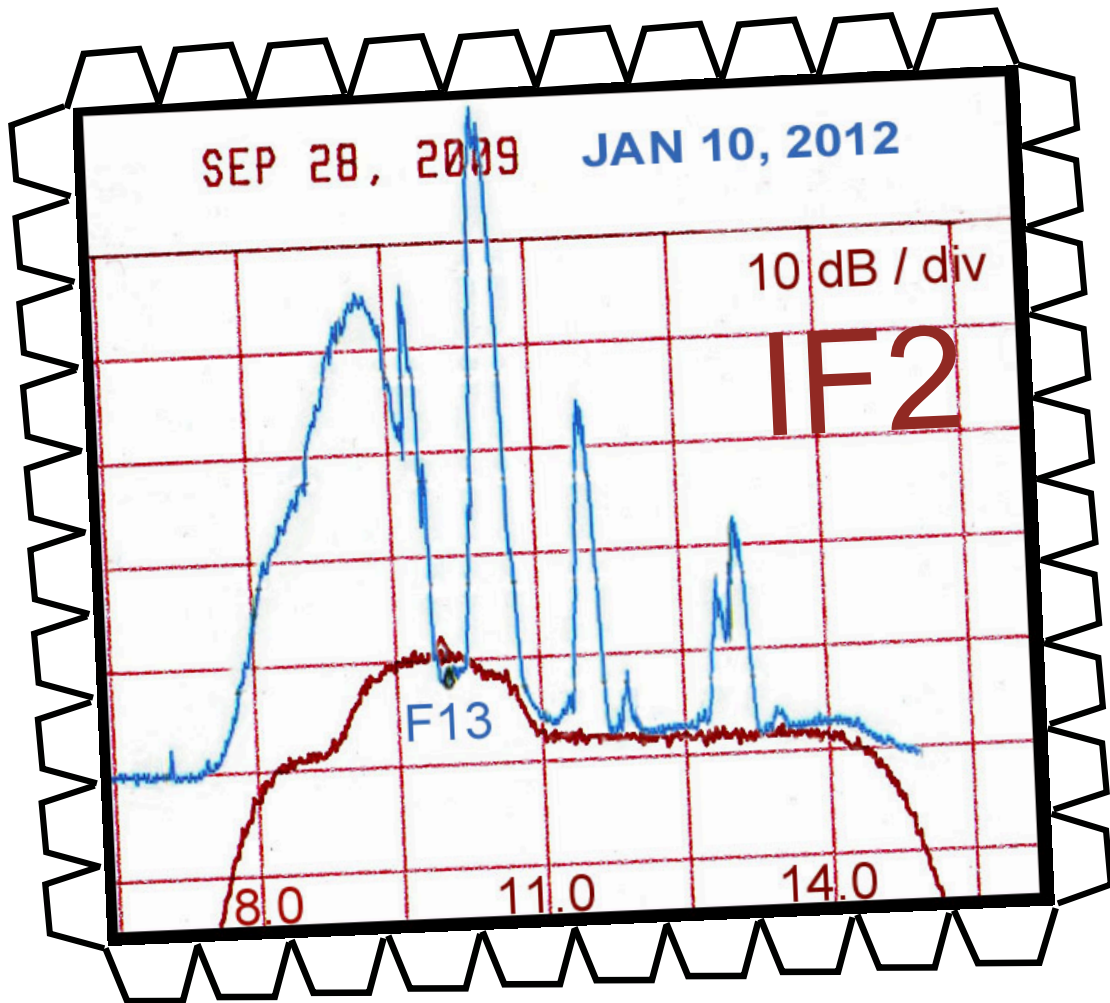
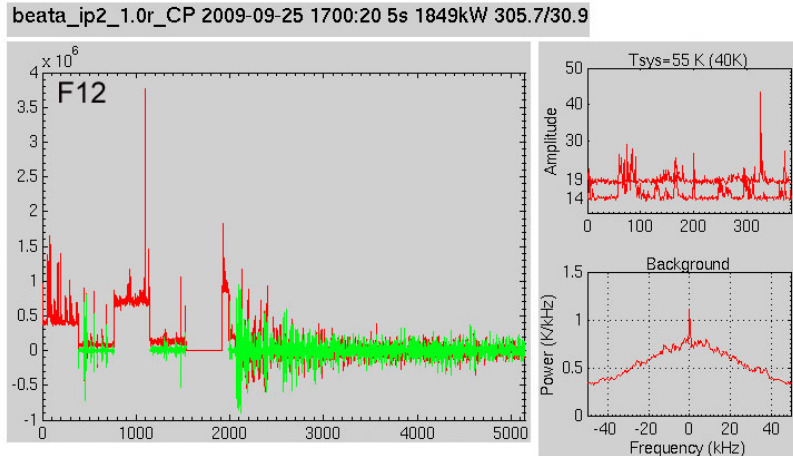
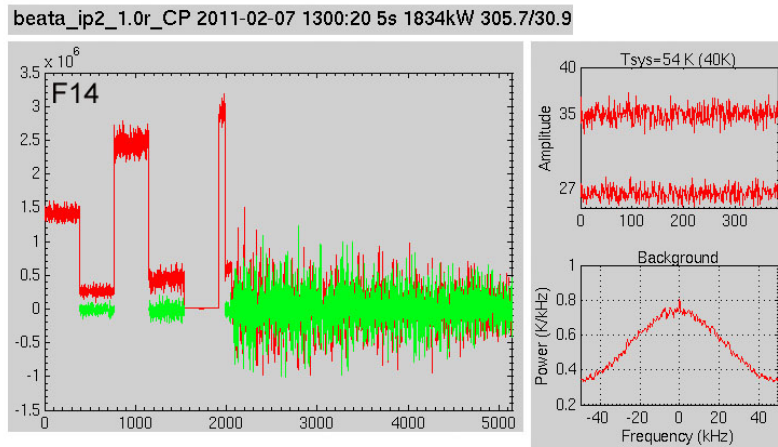

Figure 1: [Summary](#). In this composite picture of two IF2 spectra the red curve was measured in September 2009 with the antenna pointed to the direction of celestial pole. The blue curve is reproduced from Fig.22(b), measured in January 2012 in one of the *least* disturbed directions on the sky. Even in this direction, the least disturbed part of the SOD GSM band, a 200 kHz interval around the frequency F13, is not entirely free of interference. The 2012 spectrum has been shifted so that the noise levels of the two spectra roughly align over the IF2 band. It would probably still be possible to observe the incoherent scatter spectrum at F13 in this situation where the dynamic range of a 14-bit system suffices. In the standard CP1 pointing direction, the interference maxima adjacent to F13 can become 20–30 dB stronger, and then the present receiver can't cope any more. In addition, F13 itself gets more disturbed. After the loss of frequency protection, there moreover is no guarantee that mobile operators will not change the usage of their GSM frequencies at any time and in any place.



(a) September 2009.



(b) February 2011.

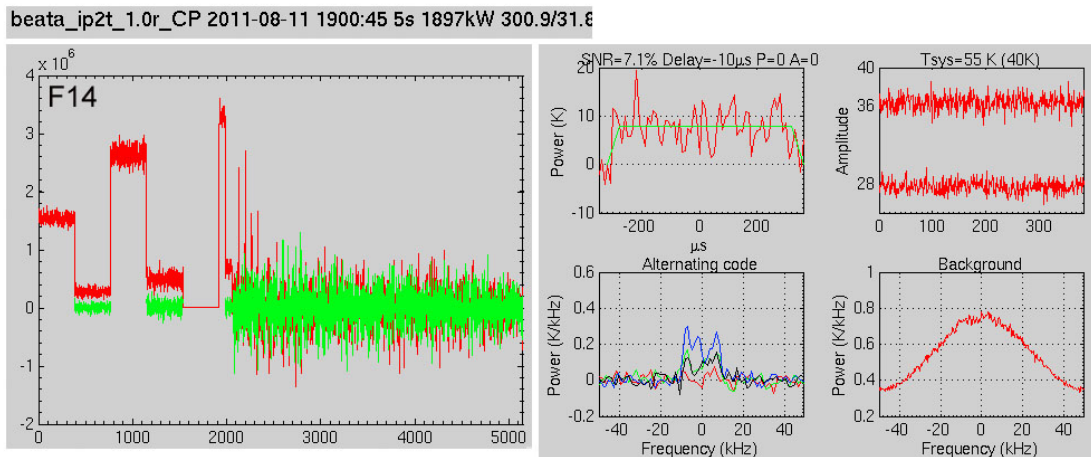

(c) August 2011.

Figure 2: [RTGRAPH displays 2009–2011](#). The experiment in these plots is the at remotes single-frequency experiment BEATA. Even with a 100 km protection zone around the Sodankylä site, there was accessional interference as in panel (a). The protection was lost in June 2010. Towards end of 2010, EISCAT started using F14 as the standard frequency for remotes.

SOD 2011-11-27 beata_cp1_1.0r_CP 0kW 305.7/29.9

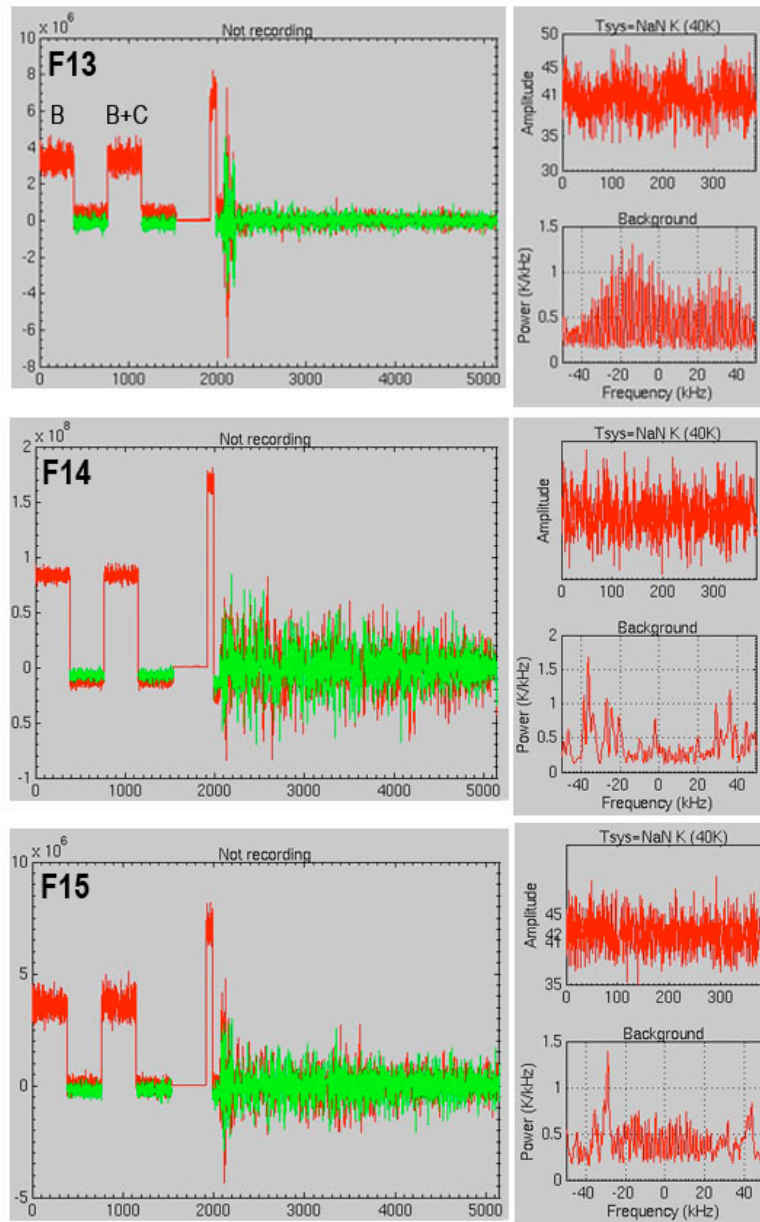
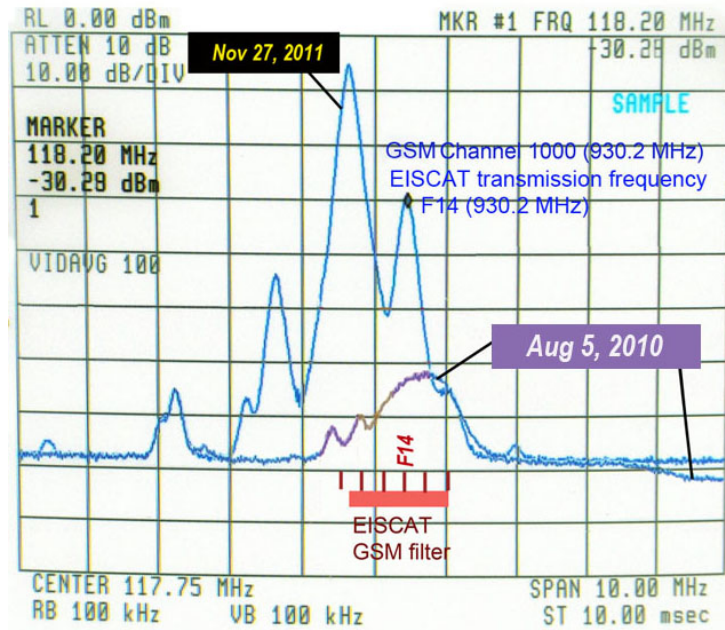
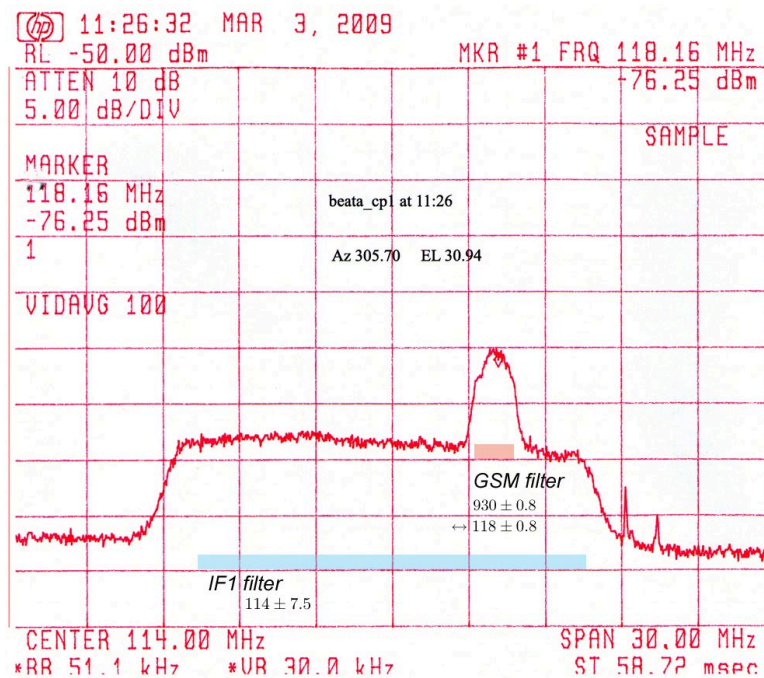

Figure 3: [RTGRAPH display of BEATA on 27 November 2011](#). We realised the new in-band interference for the first time on 27 November 2011 when testing the receiver after conversion from 1.4 GHz to 930 GHz. The three RTGRAPH plots here show BEATA data, taken a few minutes apart on the frequencies F13–F15. The alarming feature was the apparent loss of calibration noise injection, which should have been riding on top of the second of the two data blocks in the beginning of the data dumps, and the corresponding value NaN of the system temperature. Also, the background spectrum was badly disturbed. What was confusing at first sight though was that on F13 and F15, the power level as read from the RTGRAPH was not that much different from what it had been earlier; this *could* still have been just the noise injection itself gone bad.



(a) November 2011 v August 2010.



(b) March 2009.

Figure 4: IF1 spectrum in March 2009, August 2010 and November 2011. Compared to August 2010, in November 2011 there is more than 30 dB new power on top of F11, F12 and F14, and about 15 dB on top of F13 and F15. F16 appears still rather undisturbed. The dominant GSM signal, between F11 and F12, has power density more than 70 dBm above the undisturbed level. Antenna was pointed to CP1 field-aligned direction AZ 305.7°, EL 30.9°. In panel (a), both plots were taken with identical spectrum analyser settings. A zoomed-out view of the whole IF1 band in March 2009, with no obvious in-band interference, is shown in panel (b) for reference.

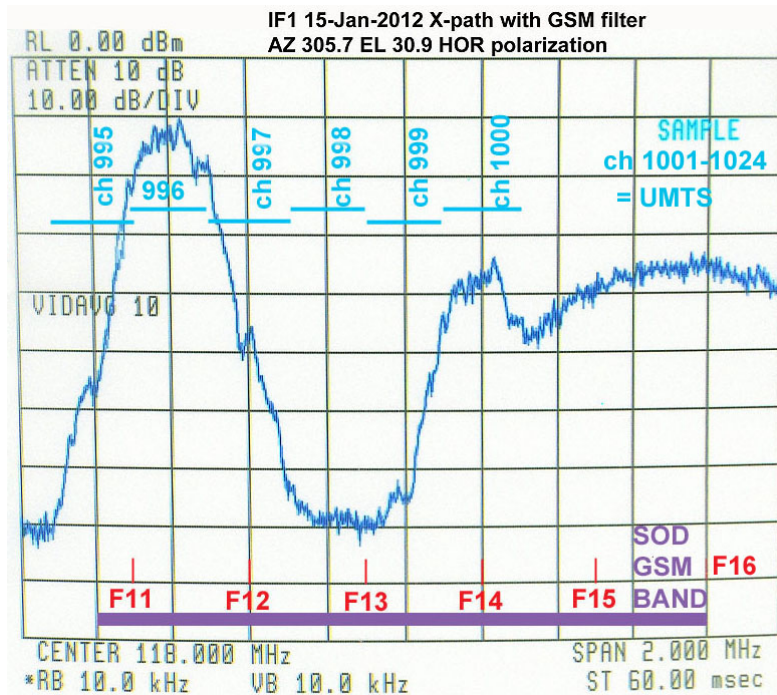

Figure 5: **GSM channels in the SOD GSM band.** Antenna was pointed to the CP1 field-aligned direction AZ 305.7°, EL 30.9° in the measurement on 15 January 2012. The 1.6 MHz wide SOD GSM band, here shown on the first IF, is marked at the bottom, together with the EISCAT UHF center-frequencies F11-F16. The 200 kHz wide channels 995-1001 of E-GSM are marked at the top. To the right of GSM channel 1000 is a block of 24 GSM, or maybe 25, channels that are used to form a single 5 MHz wide UMTS channel. The group of three GSM-channels, centred at channel 996, (929.4 MHz) is the dominant source of interference in all azimuths at this elevation, though its peak intensity at IF1 varies between about -5 dBm and -35 dBm. The power level at F13, which is sandwiched between ch 998 and ch 999, varies between about -70 dBm and -83 dBm over azimuths when measured with 10 kHz spectral resolution bandwidth.

	RF	IF1	IF2
	f	$f - 812$	$940 - f$
F0	926.0	114.0	14.0
F1	926.3	114.3	13.7
F2	926.6	114.6	13.4
F3	926.9	114.9	13.1
F4	927.2	115.2	12.8
F5	927.5	115.5	12.5
F6	927.8	115.8	12.2
F7	928.1	116.1	11.9
F8	928.4	116.4	11.6
F9	928.7	116.7	11.3
F10	929.0	117.0	11.0
F11	929.3	117.3	10.7
F12	929.6	117.6	10.4
F13	929.9	117.9	10.1
F14	930.2	118.2	9.8
F15	930.5	118.5	9.5

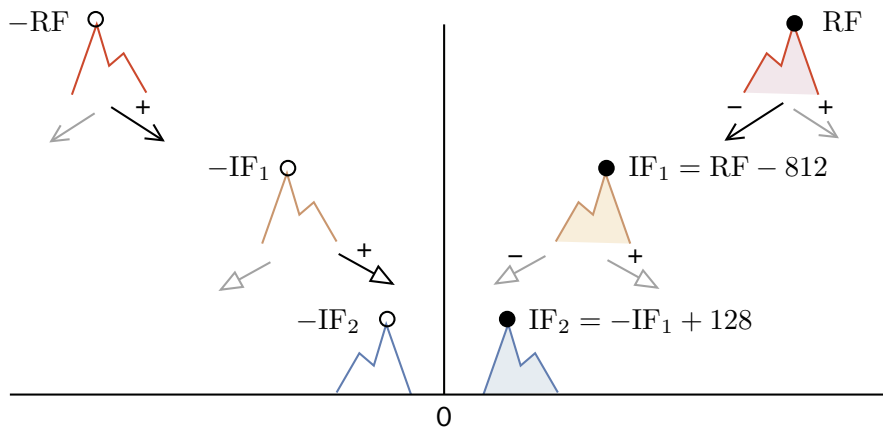

Figure 6: EISCAT UHF frequencies, and the frequency mapping in the analog receiver. After the analog receiver, the digital receiver performs demodulation to base-band by shifting via complex multiplication the IF₂ spectrum (to the left, I think) and filtering out that spectral component that is further away from DC. With these frequency translations, IF₂ spectrum is inverted with respect to RF and IF₁, so that on a spectrum analyser display of IF₂, highest RF and IF₁ frequencies map to the leftmost positions on the screen. The SOD GSM filter passes through the UHF frequencies F11 to F15. It also passes “F16” at 930.8 MHz, but that frequency cannot use in transmission.

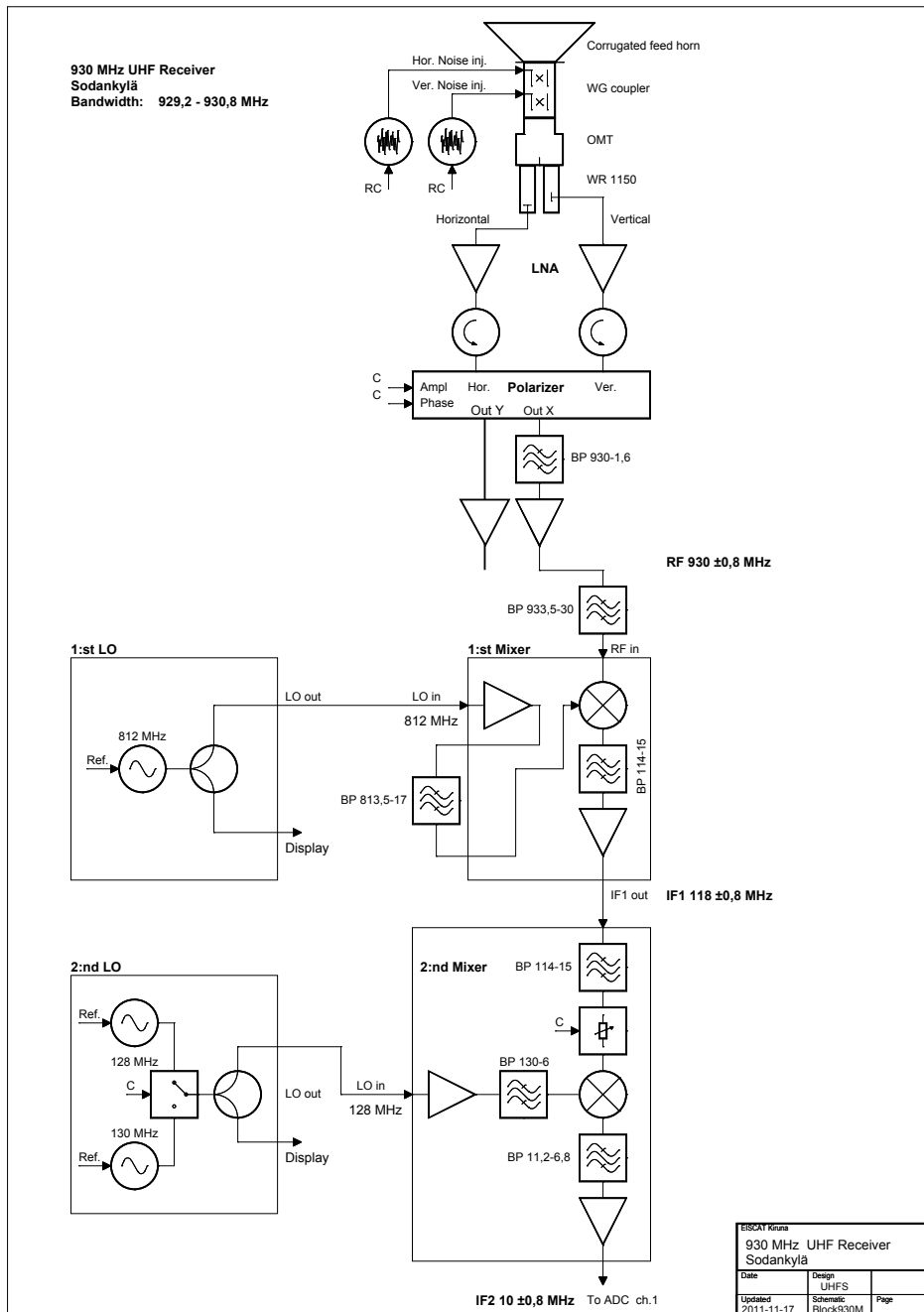
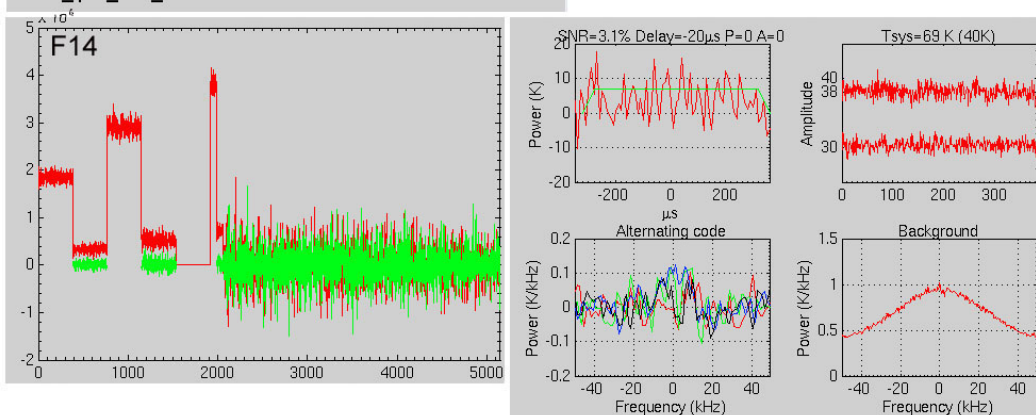

Figure 7: **Block diagram of the Sodankylä receiver.** The diagram shows only one of the two identical signal paths (“X” and “Y”) from the two polariser outputs to the two A/Ds, the X path. There is a special 1.6 MHz wide bandpass filter, centered at 930 MHz, after the polariser, referred to as the “SOD GSM filter” in this report. Normally, there is a similar GSM filters on both signal paths, but for these measurements, the filter on the Y path was disconnected. The EROS-controlled attenuator in front of the second mixer is referred to as the signal attenuator. The system’s main antialiasing filter is in front of the IF2 amplifier, and has the passband from 7.8 MHz to 14.6 MHz (113.2–120.2 MHz in terms of IF1). The diagram is courtesy of Lars-Göran Vanhainen.

beata_ip2t_1.0r_CP 2011-08-11 2200:00 5s 1908kW 312.7/29.3



(a) 20:00:00—The last echo.

beata_ip2t_1.0r_CP 2011-08-11 2200:05 5s 1909kW 301.5/31.8

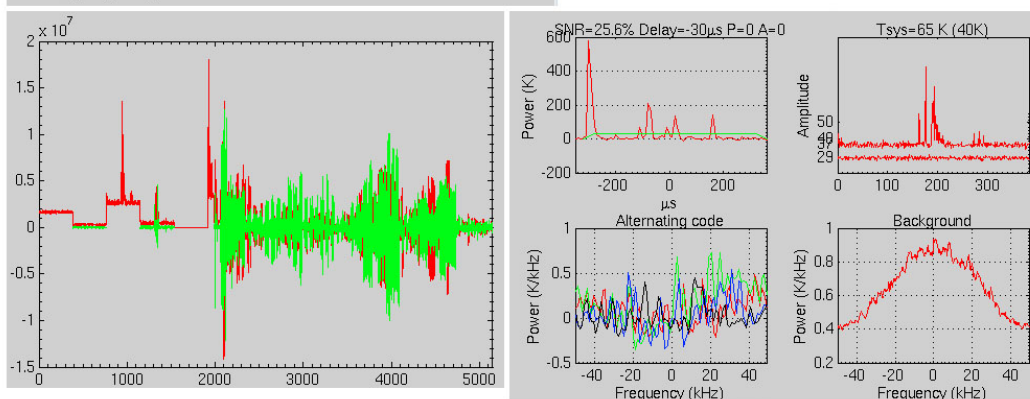

(b) 20:00:05—An interference burst.

beata_ip2t_1.0r_CP 2011-08-11 2200:25 5s 0kW 300.9/31.8

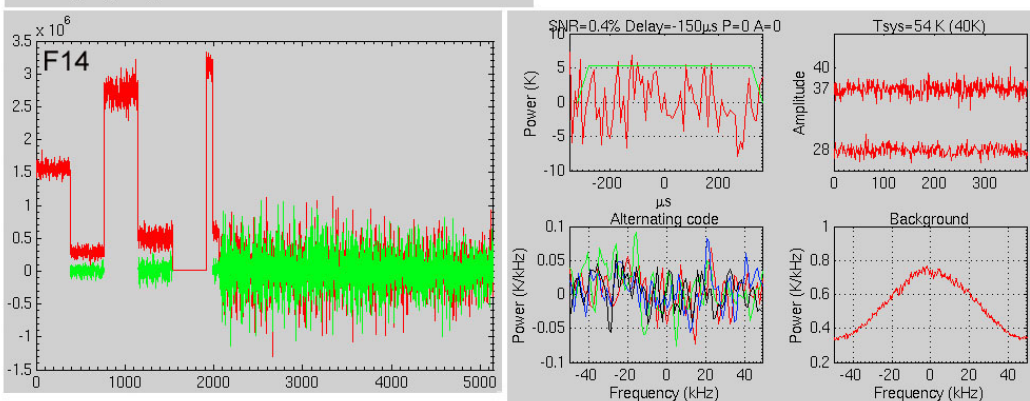

(c) 20:00:25—Transmitter is off.

Figure 8: **The last echo.** It is probable that after 30 years, minus two weeks, of UHF measurements, the last radar signal in the 930 MHz band in Sodankylä was received 11 August 2011 at 22:00:00 UT. The last recognisable IS spectrum is the one shown in the spectral plot of panel (a). At 22:00:00 the running experiment came to its scheduled end. Panels (b) and (c) show the Tromsø UHF transmitter going down the last time in a tristatic experiment.

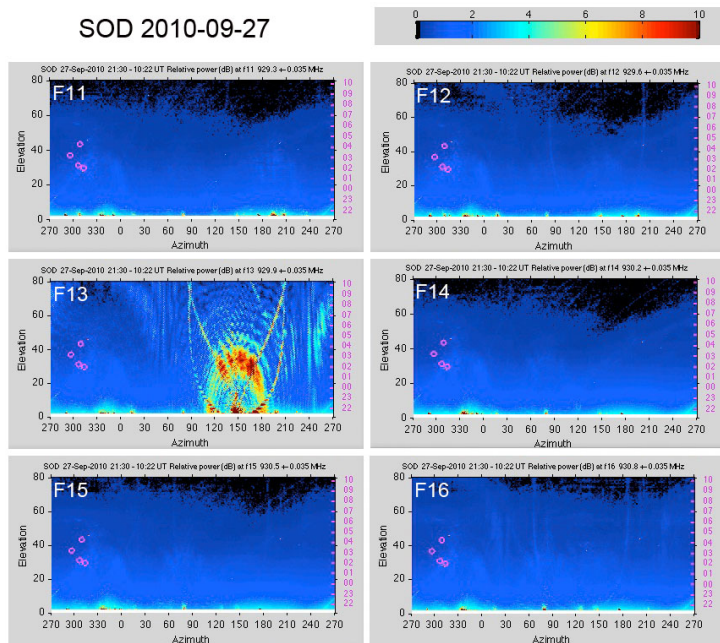
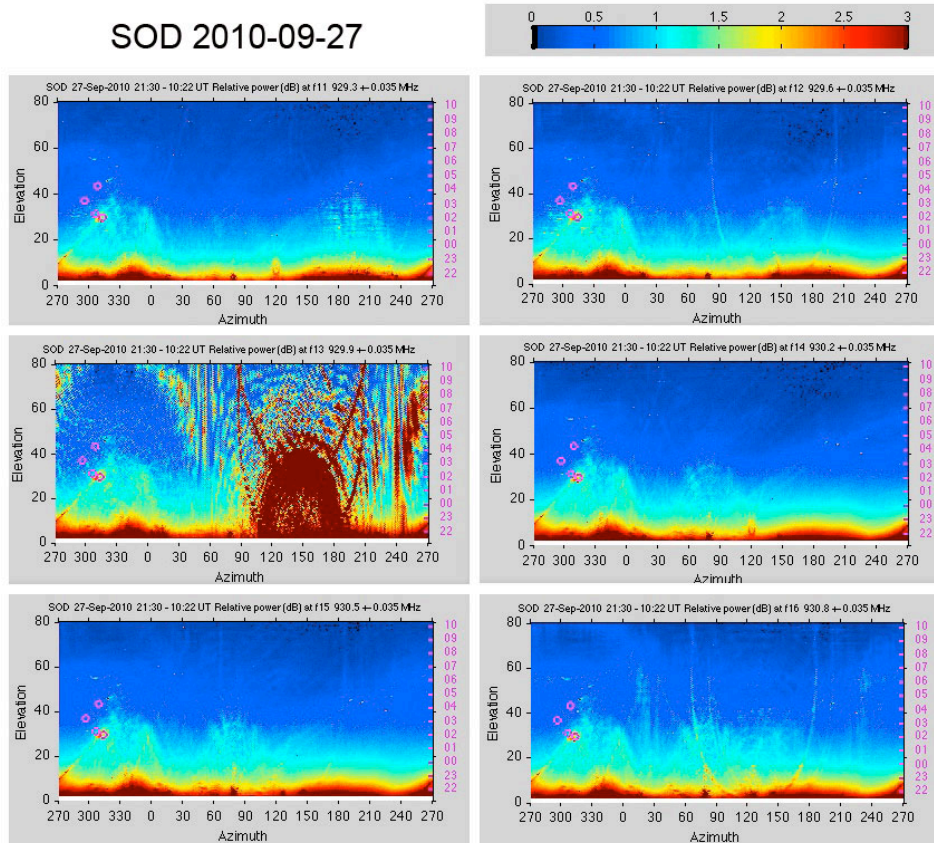
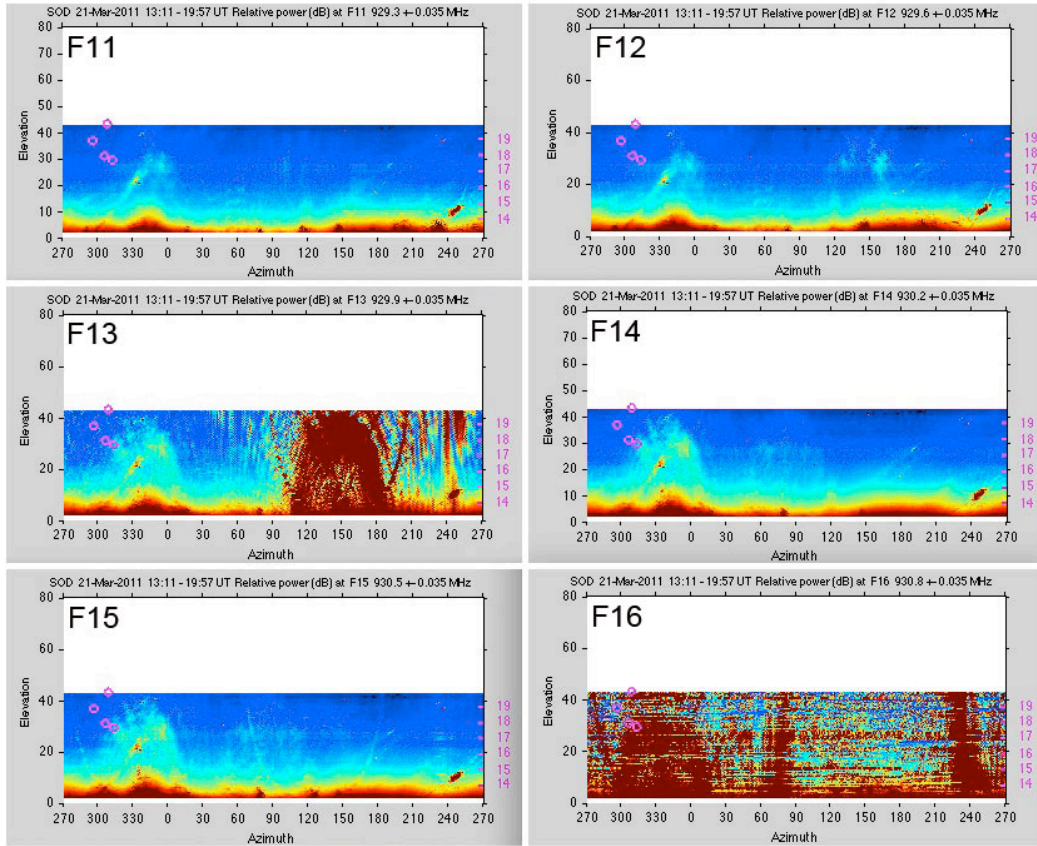
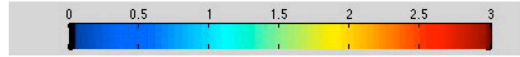

Figure 9: [Sodankylä site radio sky 27 September 2010](#). Received power on six frequencies. Three months after losing frequency protection, most of the frequencies F11–F16 in the SOD GSM band were still usable in all directions. Line-plots of the lowest-elevation azimuth scans are shown in Fig.12.

SOD 2011-03-21



(a) High sensitivity map.

SOD 2011-03-21

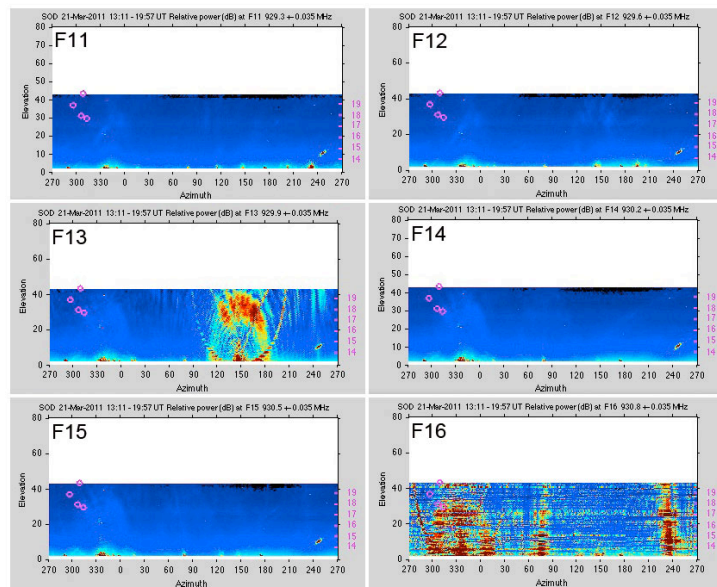
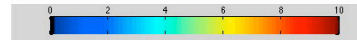

(b) Low sensitivity map.

Figure 10: Sodankylä site radio sky on 21 March 2011. Compared to September 2010, there is new interference at F16. Low-elevation scans are presented as line plots in Fig.13.

SOD 2011-09-17

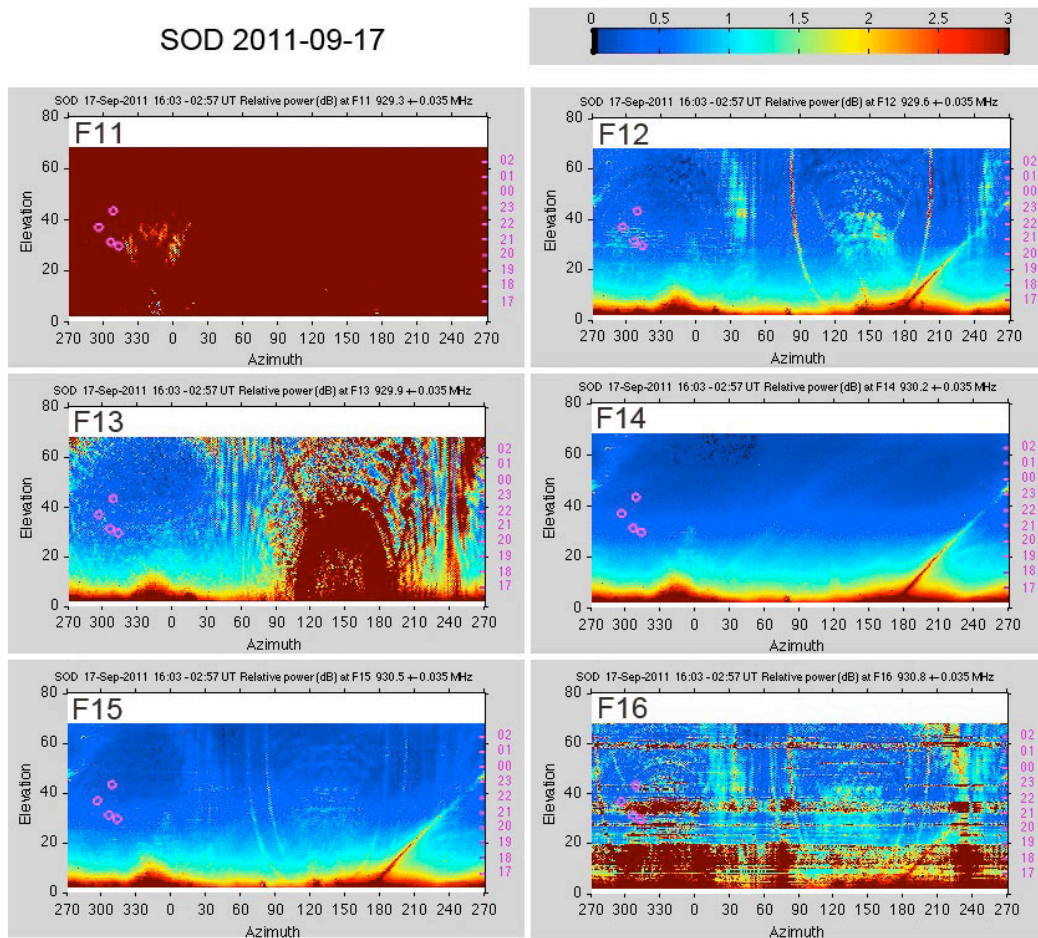

(a) High sensitivity map.

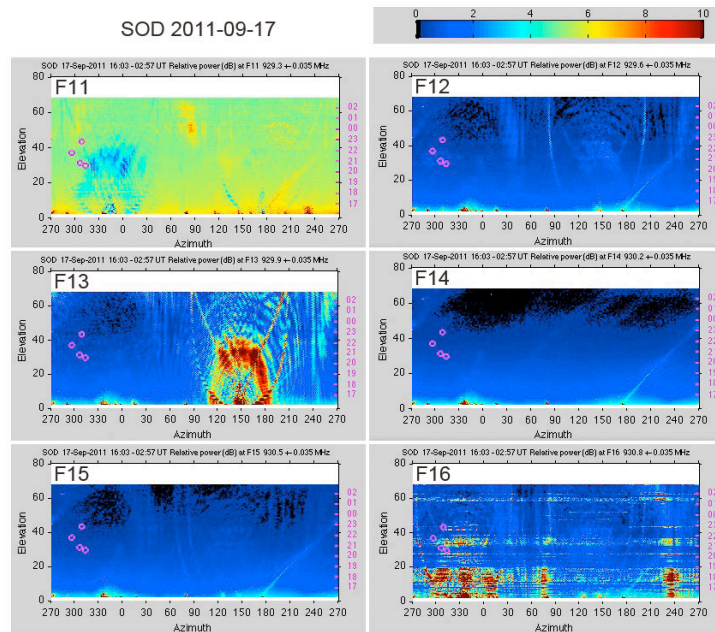

(b) Low sensitivity map.

Figure 11: Sodankylä site radio sky on 17 September 2011. Even though F11 has been lost, and F16 is going, this is still business-as-usual on F14. Low-elevation scans are shown on Fig.13.

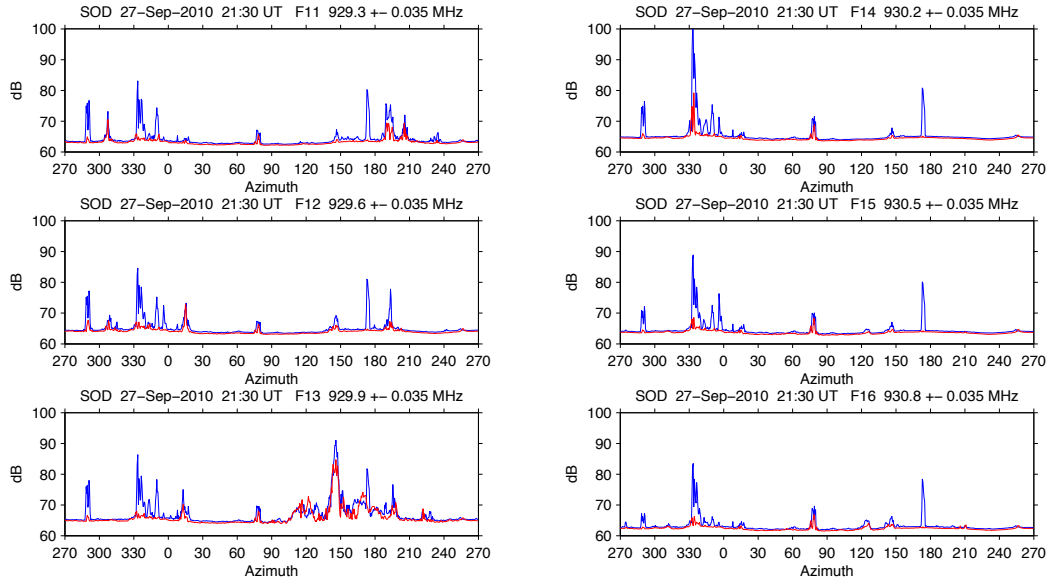

(a) September 2010: F11-F13.

(b) Sep 2010: F14-F16.

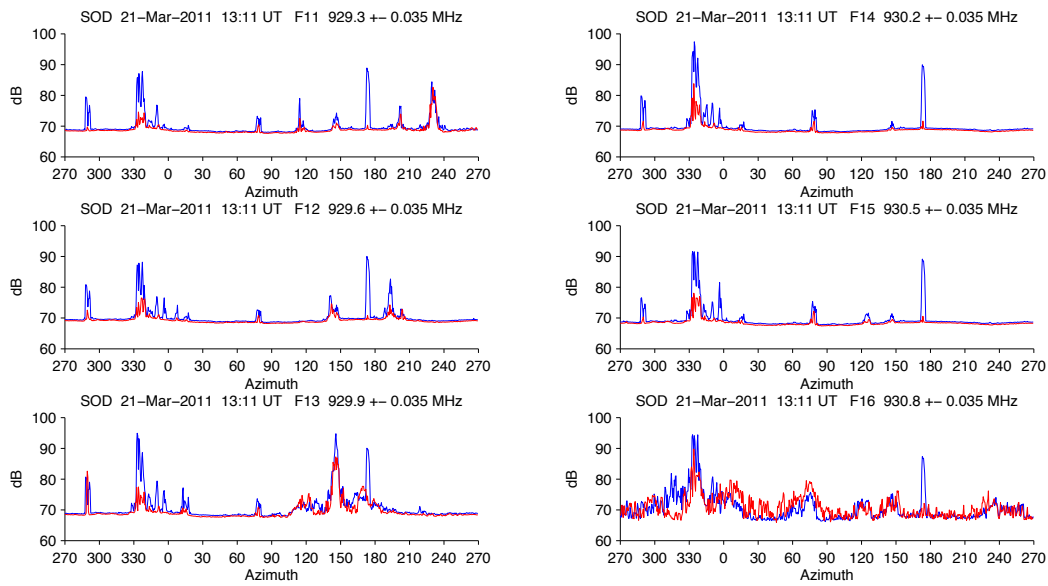

(c) March 2011: F11-F13.

(d) Mar 2011: F14-F16.

Figure 12: Sodankylä site low-elevation radio sky in September 2010 and March 2011.

The blue curves correspond to 2.0° elevation, red curves to 2.5° elevation. Between the two dates, the frequency F16 has become disturbed, and the disturbance seems to be spreading from the direction of the Sodankylä village transmitter, azimuth 334. This could be a prelude to (a trial for) DNA UMTS. There is also a general change of power level between the dates, but this probably is just due to change in receiver gain.

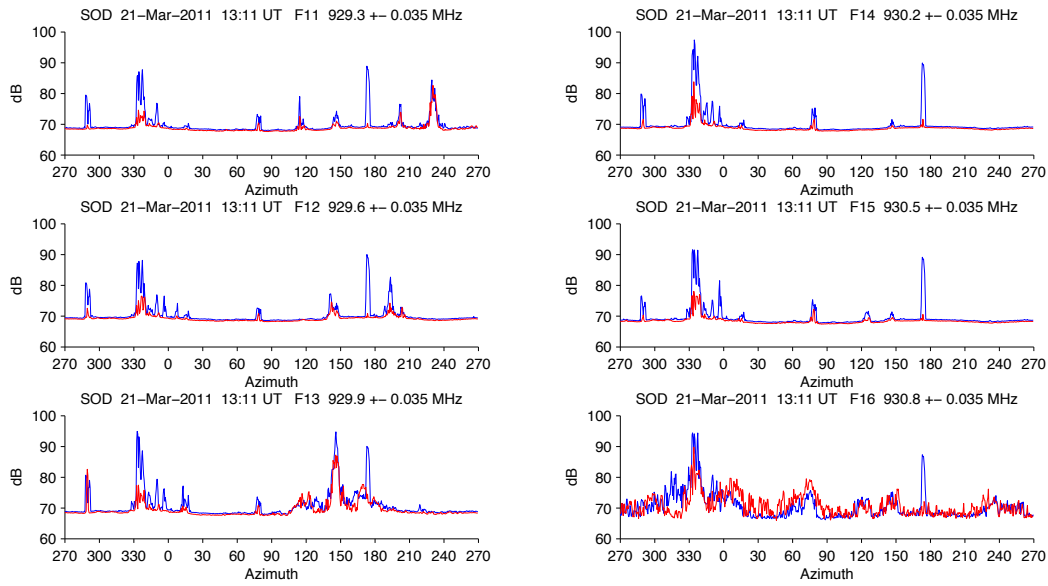

(a) March 2011: F11-F13.

(b) Mar 2011: F14-F16.

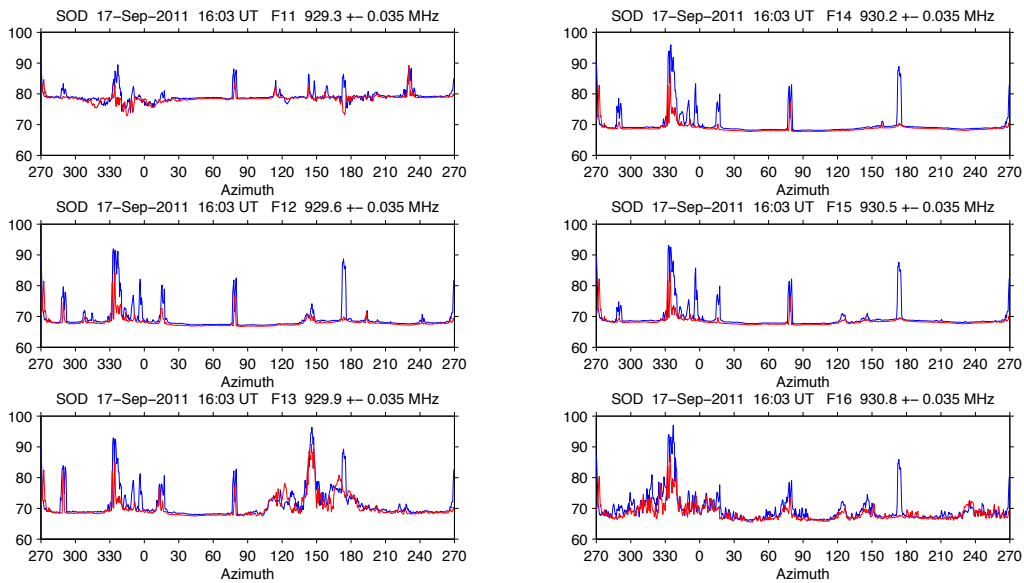

(c) September 2011: F11-F13.

(d) Sep 2011: F14-F16.

Figure 13: Sodankylä site low-elevation radio sky 21 March 2011 and 17 September 2011. The blue curves correspond to 2.0° elevation, red curves to 2.5° elevation. Between these dates, at F11 the “background” has risen by about 10 dB in almost all azimuths. It is not immediately obvious why and how this has happened. A new transmitter has appeared to the west, and the transmitter in the east has been boosted.

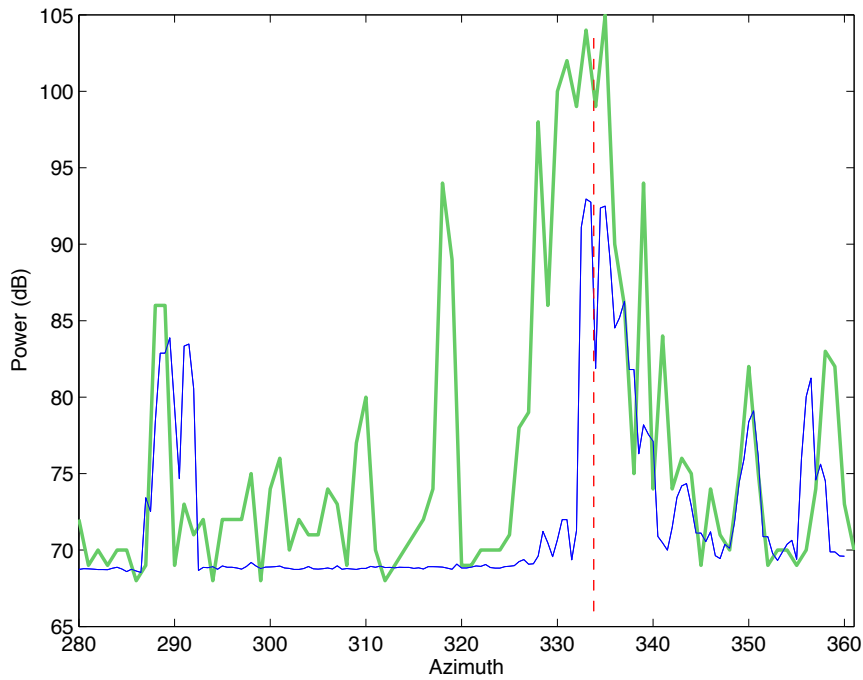

Figure 14: [Azimuth scan in January 2012 v. September 2011](#). The thick, green line is from a manually performed azimuth scan at 2° elevation in January 2012. Received power density at the frequency F13 was estimated with a spectrum analyser on the first IF level. The maximum in this plot is at azimuth 335° . The thinner, blue curve is the power density from the radio-sky mapping done in September 2011, same data as in Fig.13. The baseline level of the January data has been shifted to correspond roughly to the baseline level of the September data. The dashed red line marks azimuth 333.8° , which is the azimuth angle to a radio mast in the Sodankylä village, 6.1 km from the EISCAT antenna. The maximum power splits into two peaks. This probably is not a coincidence but shows that the interference comes in via some of the side lobes of the antenna, not through the main lobe. It could be the first side lobe, which has its maximum at 1.4° off the optical axis, but it is impossible to say for certain because the antenna pointing accuracy at low elevations is not known.

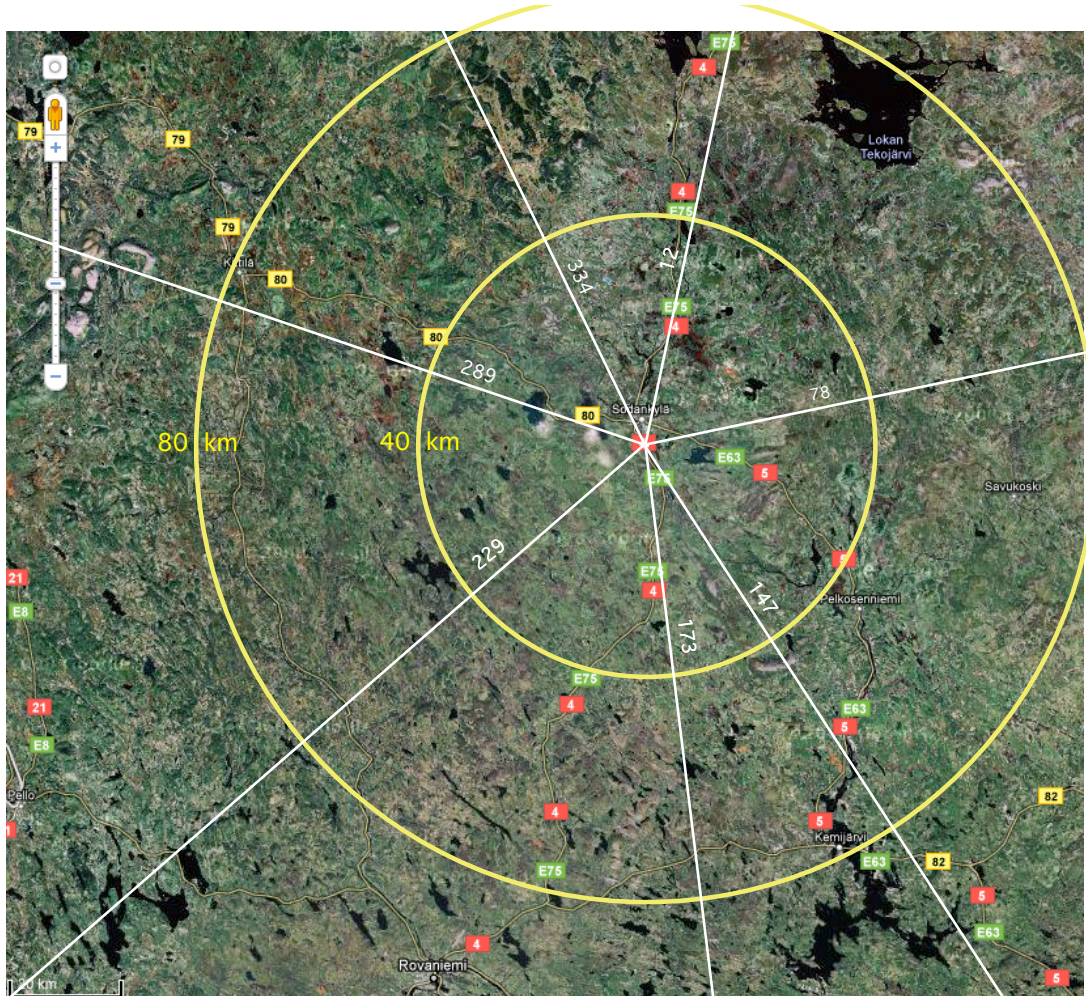

Figure 15: **Direction map of strong interference.** Directions of some of the major peaks in the site's low-elevation interference maps, Fig.12–14, are sketched here. The most harmful, in-band, interference appears to come from a mast located where the azimuth 334° line crosses the main road 80, south-west from the centre of the Sodankylä village and 6.1 km from the site, see also Fig.17. Azimuth 12 is not far from azimuth 15° which is the direction to a mast north-east from the Sodankylä village, on the hill Kuolpuvaara, 7.8 km from the site. This mast gave the main trouble in late 1980s during the era of NMT interference. Azimuth 78° picks a mast alongside main road 5 north of lake Orajärvi, at the distance of 8.9 km from the site. The azimuth labelled 147 corresponds to a major TV- and radio mast on top of the 500 m high mountain Pyhätunturi. According to EISCAT pointing geometry program, the Pyhätunturi masts (there are two) actually are at azimuth 146, at the distance of 46 km. Azimuth 173 shows the way to a mast on the hill Käyräsvaara along the main road 4, at azimuth 173.2° and the distance of 13.7 km from the site, a strong source in the interference maps. All these masts reach high enough altitude to be conceivably visible already via the first side-lobe when the antenna is formally pointed to 2° elevation. In the case of the Käyräsvaara mast the difference in the elevation 2° and elevation 2.5° power is so large, about 20 dB, that it seems possible that the source actually is seen near the centre of the antenna beam. This would indicate a worryingly large pointing calibration error (or a *very* high mast).

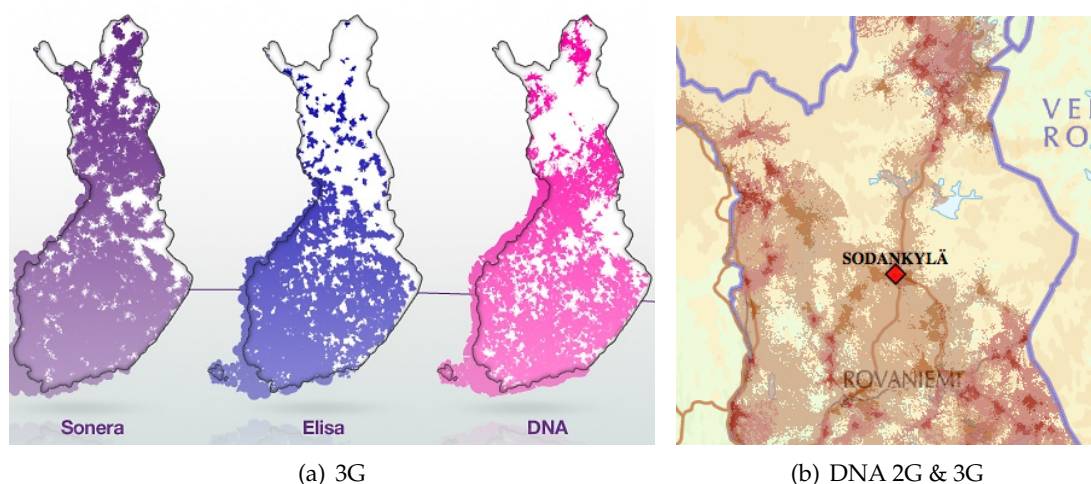

Figure 16: **3G coverage of the three nationwide operators.** Panel (a) is from Sonera web page in February 2012 and shows 3G coverage. The web page states that for Elisa and DNA, the coverage maps are taken from their respective web pages as of 3 October 2011. DNA would appear to have coverage in Sodankylä already at that date. Panel (b) is from DNA web page in Feb 2012 and shows both DNA 2G and 3G coverage as of 12 December 2011, with colour coding as in Fig.17. The DNA 3G coverage along the main road 5 South-East from Sodankylä that is marked in panel (a) seems to be missing in panel (b). The 200 km wide EISCAT protection circle has left an unfair hole in the DNA 3G, but not 2G, coverage in much of central Lapland.

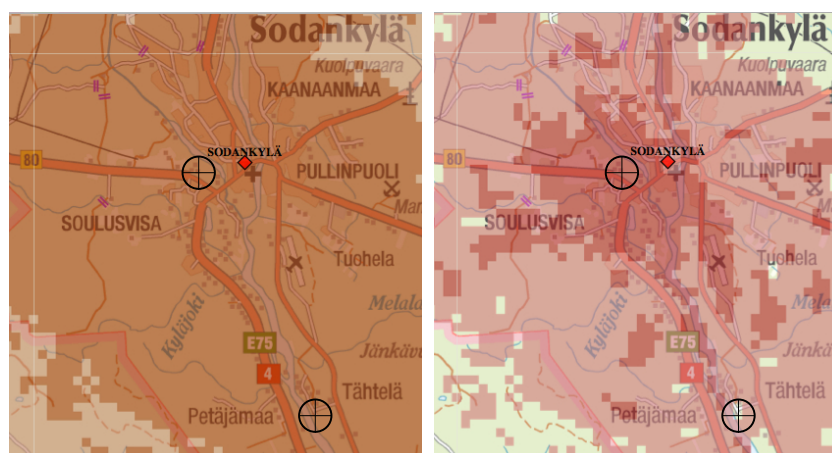

Figure 17: **Coverage of DNA mobile services in Sodankylä in December 2011.** The left panel is for 2G services, with the darker colour indicating EDGE coverage. The right panel shows UMTS900 coverage, the darker red without and the lighter with an external antenna. The crosshair in Tähtelä shows the location of the EISCAT antenna. The crosshair in Sodankylä village pinpoints a radio mast at azimuth 333.8° and range 6.1 km from the EISCAT antenna. That mast, which is directly visible from the EISCAT antenna, appears to be the source of the strongest in-band interference in the SOD GSM band.

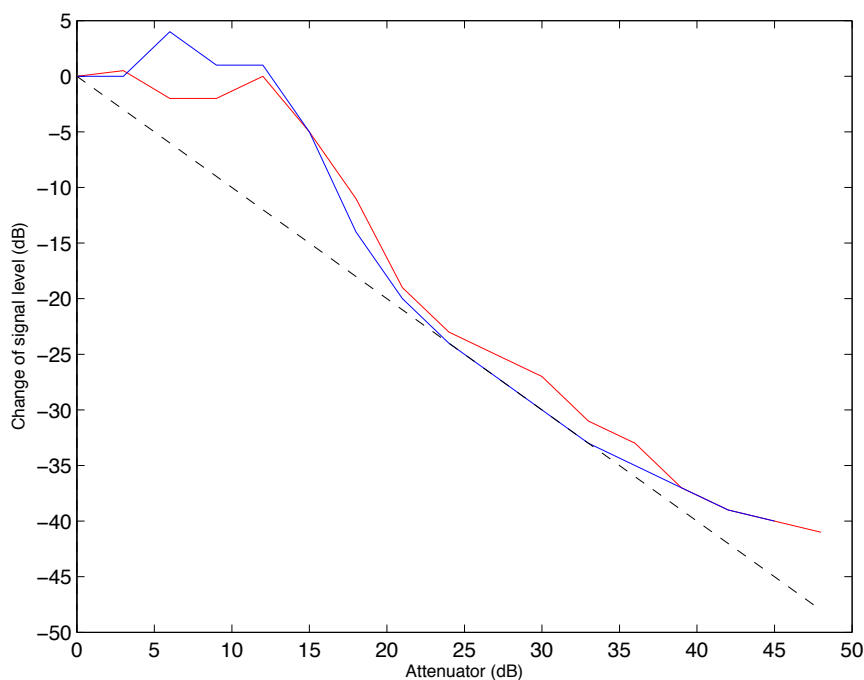

Figure 18: **IF2 output voltage v. attenuator setting.** The red and blue curves are the outputs of the two identical paths through the receiver's IF2 unit, Fig.7. The output power density at the frequency F13 was, tediously and with at least ± 1 dB uncertainty, estimated from spectrum analyser displays similar to those shown in Fig.19, when the signal attenuator setting was changed via EROS. In the two measurements, the same IF1 output cable was connected to the IF2 box. The dashed line is the expected behaviour. It appears that the IF2 unit is in full saturation until at least about 15 dB of signal attenuation is used. And much more attenuation is needed to decrease the IF2 output to a level suitable for input into the A/D converter. For instance, in the CP1 antenna pointing direction, one needs to use about 35 dB of signal attenuation before the IF2 output is within the ± 1 V required. For many years the standard attenuator setting for all pointing directions has been 4 dB. The two IF2 paths behaved roughly similarly, which probably means that neither the attenuators nor the IF2 amplifiers themselves were damaged (yet).

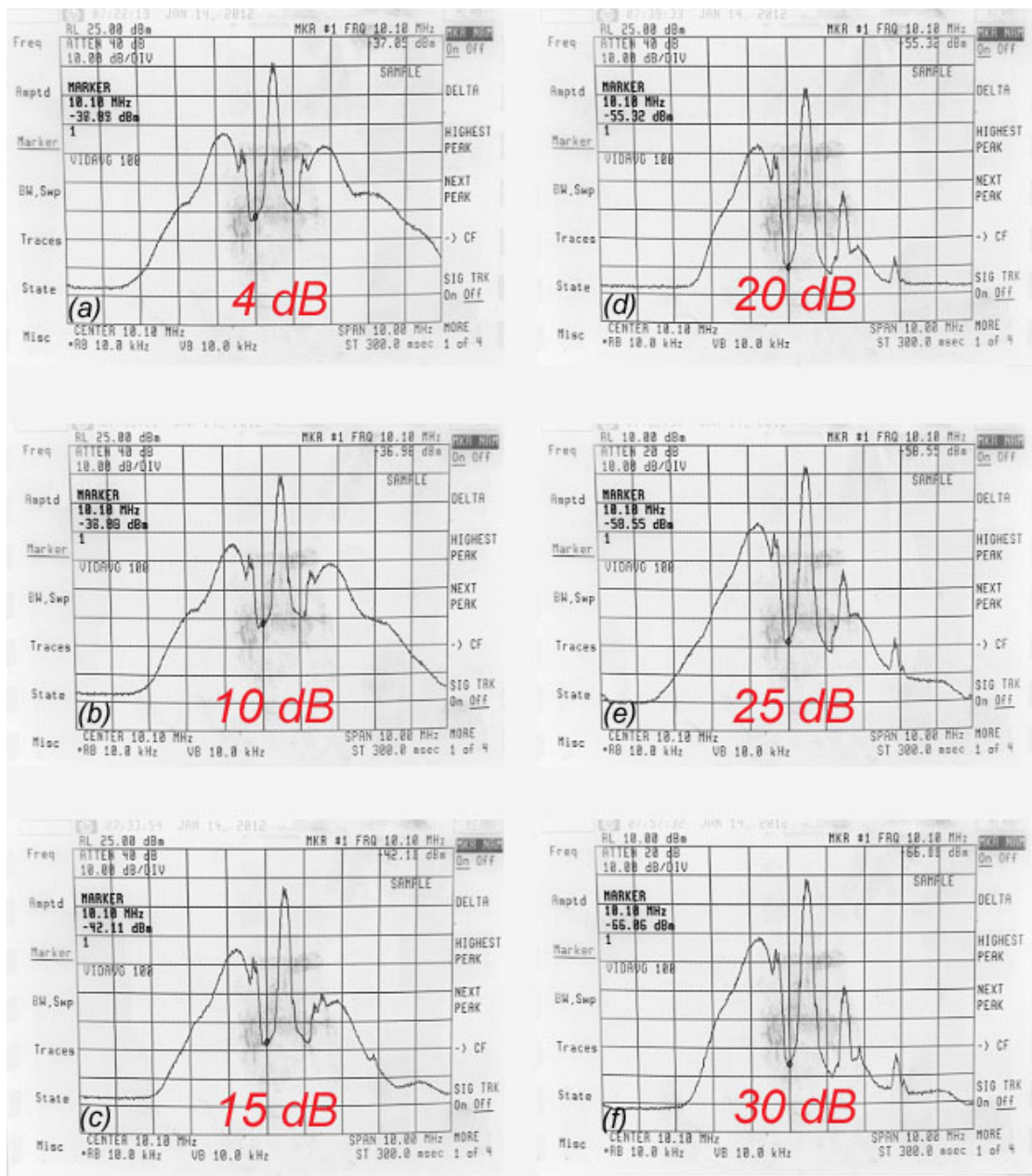
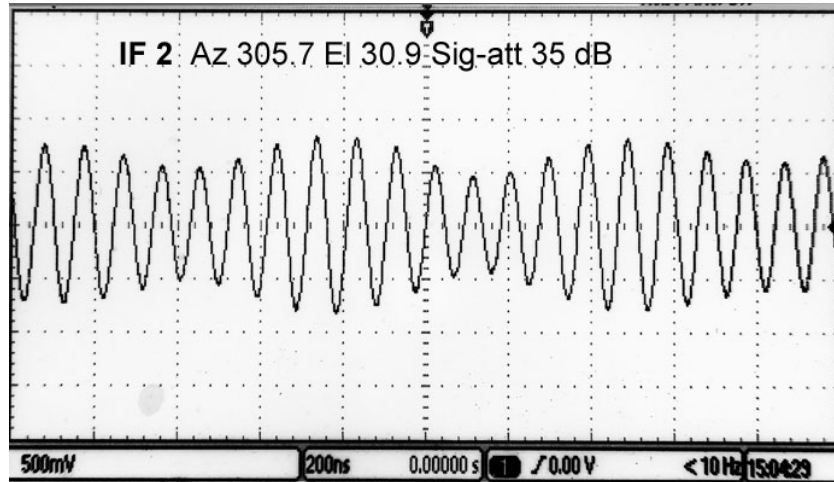
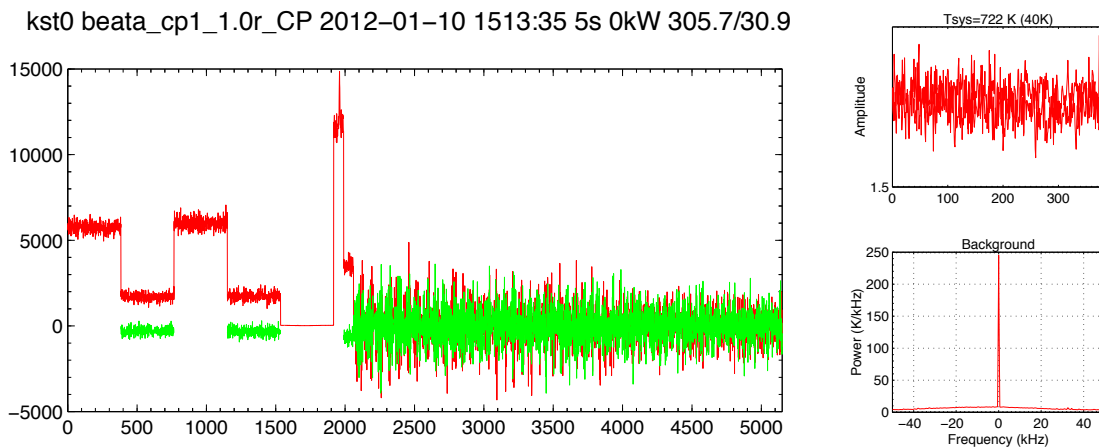

Figure 19: **IF2 spectrum v. attenuator setting.** Antenna was pointed to the CP1 field-aligned direction AZ 305.7°, EL 30.9° in this 14 January 2012 test. The centre frequency 10.1 MHz, with the analyser's marker attached to it, corresponds to the EISCAT frequency F13. In this pointing direction, more than 20 dB of attenuation was needed before the spectral shape started to settle to something sensible. With low attenuator settings, when the IF2 amplifier is driven to compression, a strong intermodulation distortion results: The second harmonic $2f_1$ of the dominant GSM signal $f_1 \approx 10.5$ MHz mixes with the strong UMTS f_2 ($f_2 \lesssim 9.5$ MHz) to yield an in-band mixing product at $2f_1 - f_2 \gtrsim 11.5$ MHz.



(a) IF2 voltage.



(b) RTGRAPH of F13.

Figure 20: **BEATA in CP1 direction when enough attenuation is used.** Panel (a) shows a 2000 ns snapshot, taken from a scope display, of the IF2 voltage when signal attenuator has been set to 35 dB. With this much attenuation, the voltage stays within the ± 1 V required by the A/D converter. With this time resolution, the voltage, representing a 7.5 MHz wide IF2 band, would normally look like incoherent noise. But now it is entirely dominated by the spectrum-wise much narrower, hence time-wise roughly sinusoidal, GSM signal at about 10.5 MHz. Panel (b) is an RTGRAPH display of the BEATA experiment, where the digital receiver was tuned to the minimally disturbed frequency F13, 10.1 MHz. Noise injection power, the data block around x-value 1000 in the display, is just and just measurable on top of the background power and corresponds to system temperature of 720 K in this particular data dump. The large attenuation applied uniformly over the whole analog band results in very low digital signal level on the quiet F13-channel. The sampled signal on F13 excites only the lowest 3 to 4 storage bits, making quantisation noise a real issue. The low power level also results in a prominent DC spike in the background spectrum, which comes about because the digital receiver has a digital DC offset of -1.

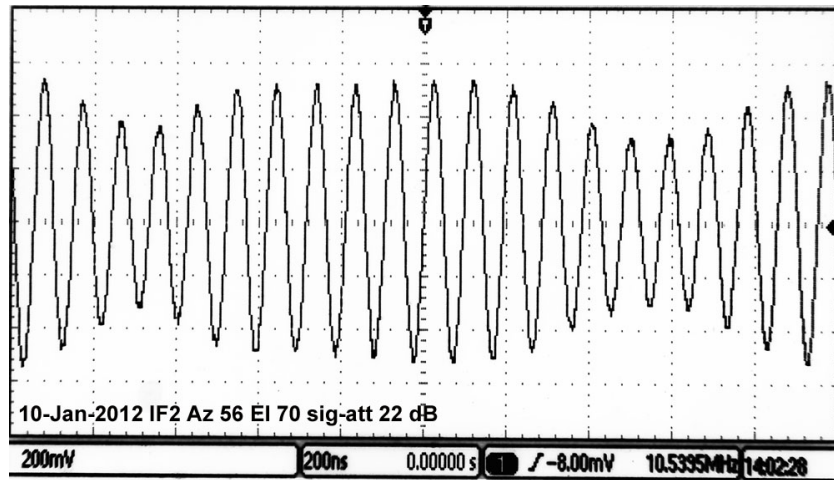

(a) IF2 voltage.

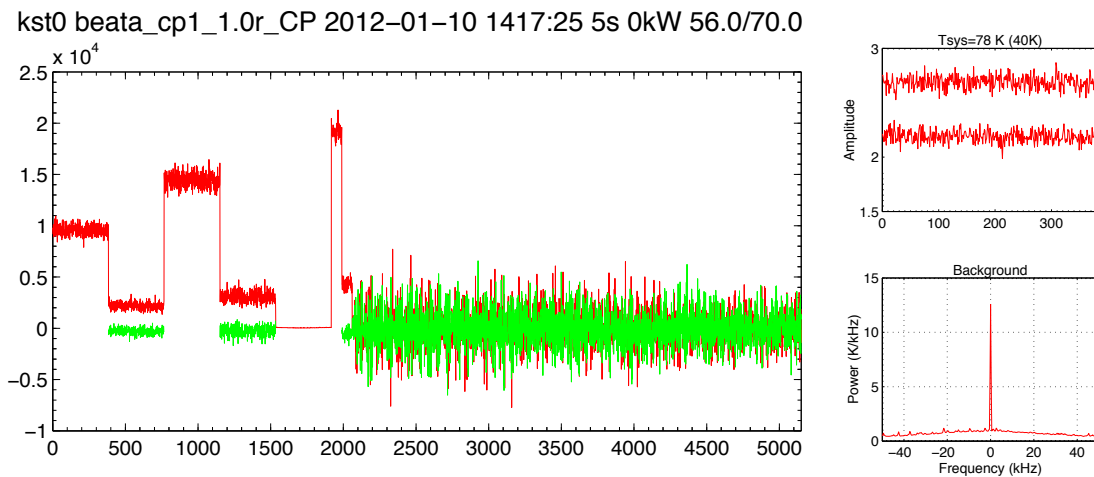

(b) RTGRAPH of F13.

Figure 21: **BEATA in a relatively undisturbed direction with enough attenuation.** The measurement was done on 10 January 2012. The figure is in same format as Fig.20. The direction AZ 56° , EL 70° is one of the pointing directions which, with enough signal attenuation, still give a decent system temperature, though of course only at the frequency F13. The GSM signal at 929.4 MHz from the base station in Sodankylä village seems to dominate the received power in all pointing directions, but there are considerable variations. In this case, 22 dB signal attenuation was required to get IF2 voltage to the A/D converter's range. Less attenuation results in less quantisation noise in the digital receiver. Probably also contamination (by whatever) at F13 is reduced. A system temperature of about 80 K is achieved, only about twice the pre-interference value. IF2 spectrum for this situation is shown in Fig.22(b).

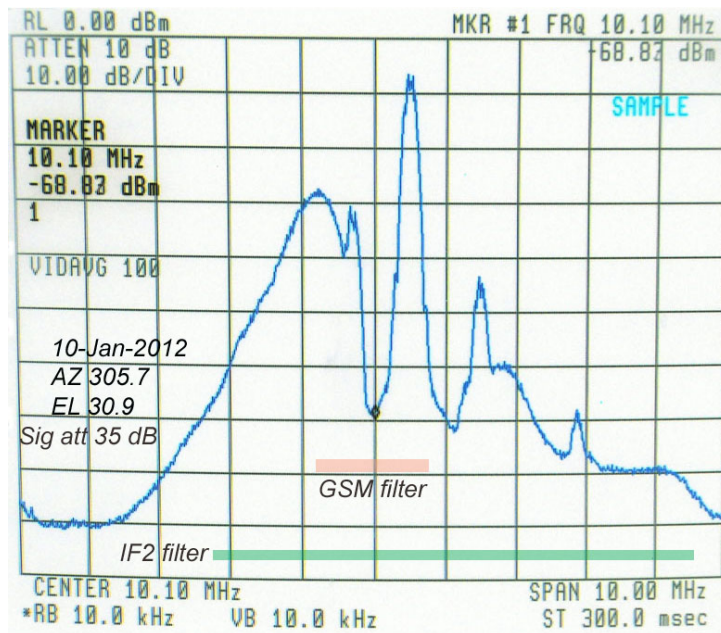

(a) CP1 direction with 35 dB signal attenuation.

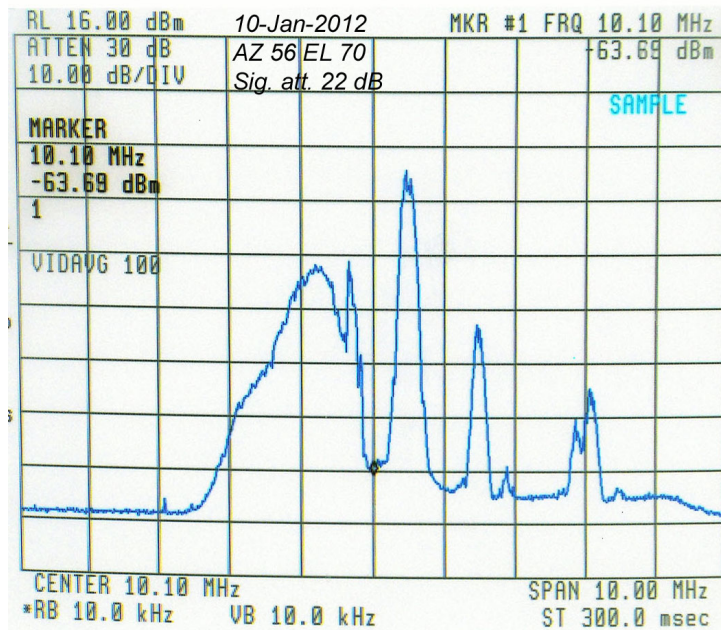

(b) A "quiet" direction with 22 dB signal attenuation.

Figure 22: **IF2 spectrum in two pointing directions.** The CP1 direction is AZ 305.7°, EL 30.9°, the "quiet" direction is AZ 56°, EL 70°. The dominant in-band interference, GSM channel 996, is about 15 dB stronger in the CP1 direction than in the quiet direction. From the F13 MARKER readings and taking the signal attenuator into account, the power level at F13 is about 8 dB higher in the CP1 direction than in the quiet direction.

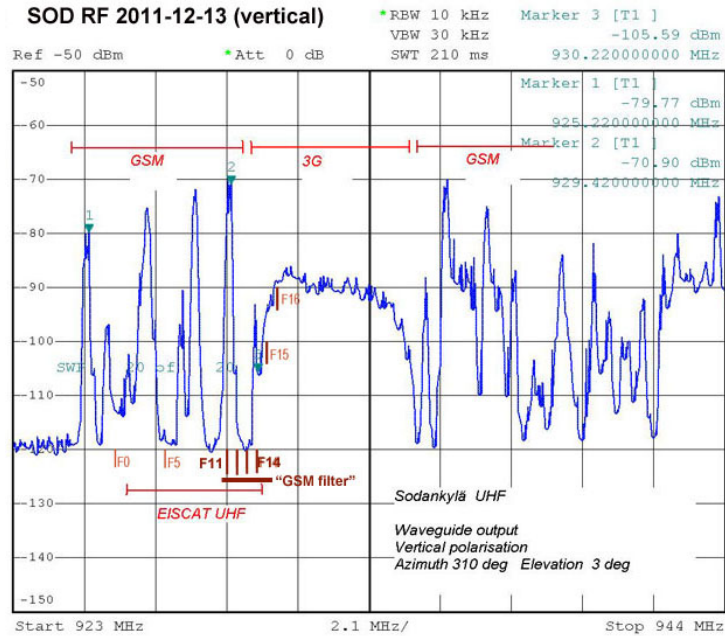

(a) RF at waveguide output.

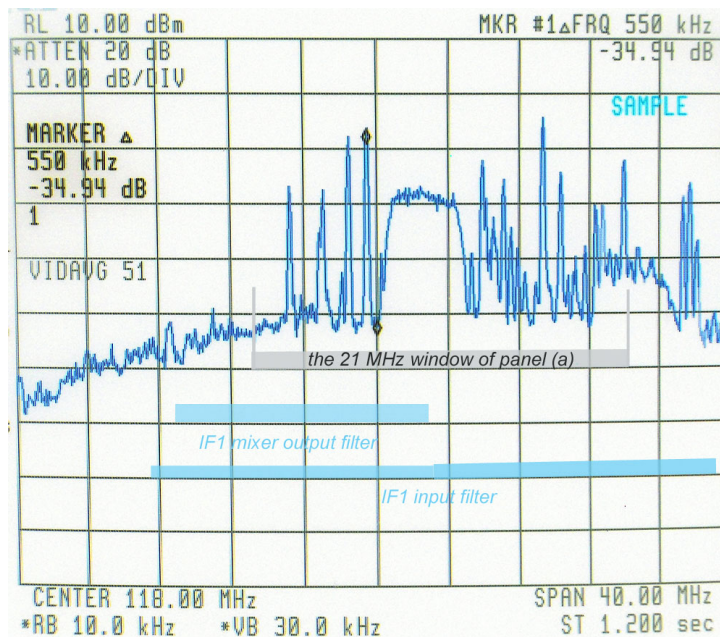

(b) First IF on the Y-path, without the GSM filter.

Figure 23: **IF1 v. RF when GSM filter is not used.** Both measurements were done at AZ 310°, EL 3°, with vertical polarisation. The RF data are from 12-Dec-2011, the IF1 data are from 13-Feb-2012. The IF1 spectrum is measured on the Y-path of the receiver which did not have the GSM filter. The flat base level at -120 dBm of the RF spectrum perhaps is determined by the spectrum analyser's sensitivity rather than the actual incoming power density. The power density variations in the RF plot are larger, by about 10 dB, than in the IF1 plot. In the RF1 plot, to the right of the IF1 filter the base level should be sloping down, but does not, while the envelope of the power peaks does. These things suggest problems in the receiver's IF1 unit when the GSM filter is not in use. Plot (a) is courtesy of Lars-Göran Vanhainen.

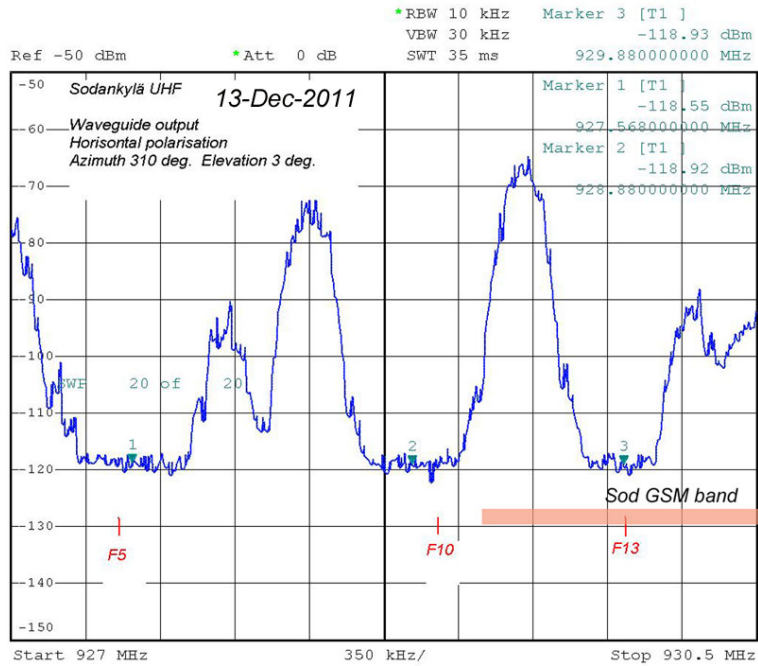

(a) RF, at waveguide output.

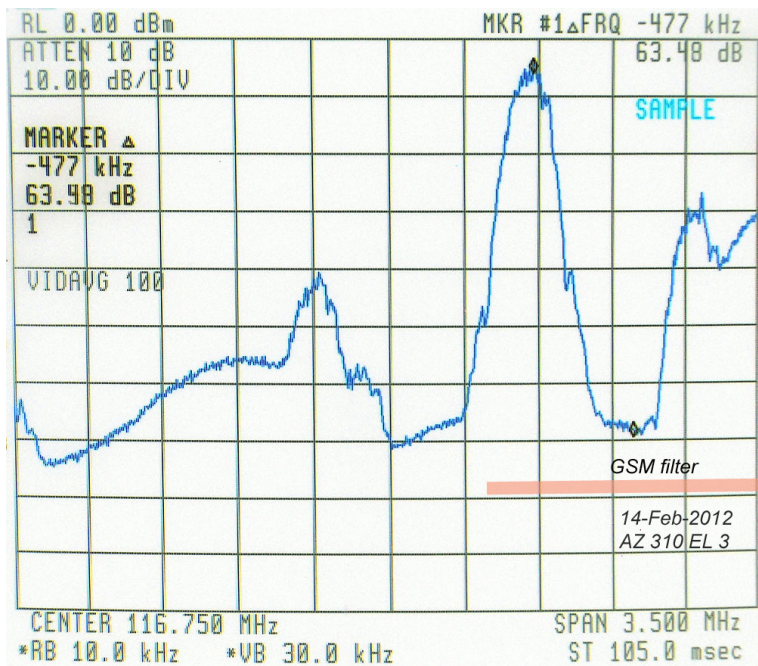

(b) IF1, at input to the IF2 unit.

Figure 24: IF1 v. RF at waveguide output. Both measurements were done at AZ 170°, EL 3°, on the X path with the GSM filter, on 13 December 2011 and 14 February 2012. Plot (a) is courtesy of Lars-Göran Vanhainen.

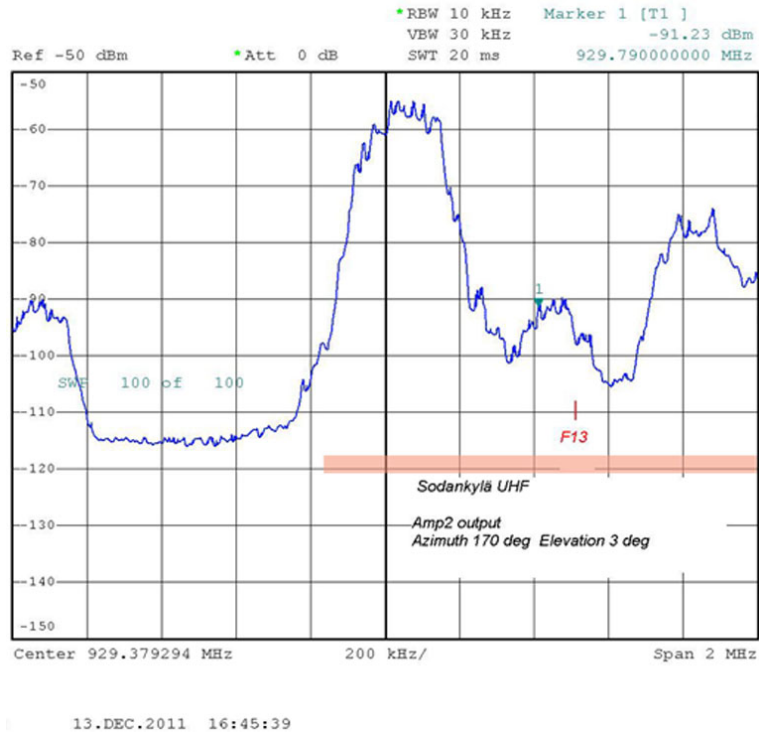

(a) RF, at input to the IF1 unit.

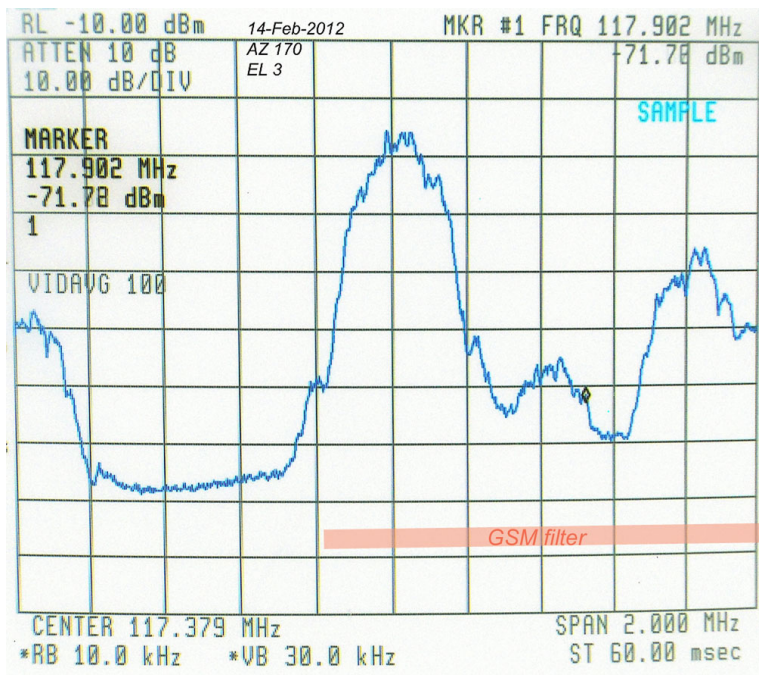

(b) IF1, at input to the IF2 unit.

Figure 25: **IF1 v. RF at IF1 unit's input.** Both measurements were done at AZ 170°, EL 3°, on the X path with the GSM filter, but two months apart in 13 December 2011 and 14 February 2012. The two spectral shapes are quite similar, with a gain difference of about 25–27 dB. The first IF unit appears to work properly when the GSM filter is used in front of it. Even in this pointing direction, 163° away from the Sodankylä transmitter, the GSM channel 996 is the dominant in-band interference. Plot (a) is courtesy of Lars-Göran Vanhainen.

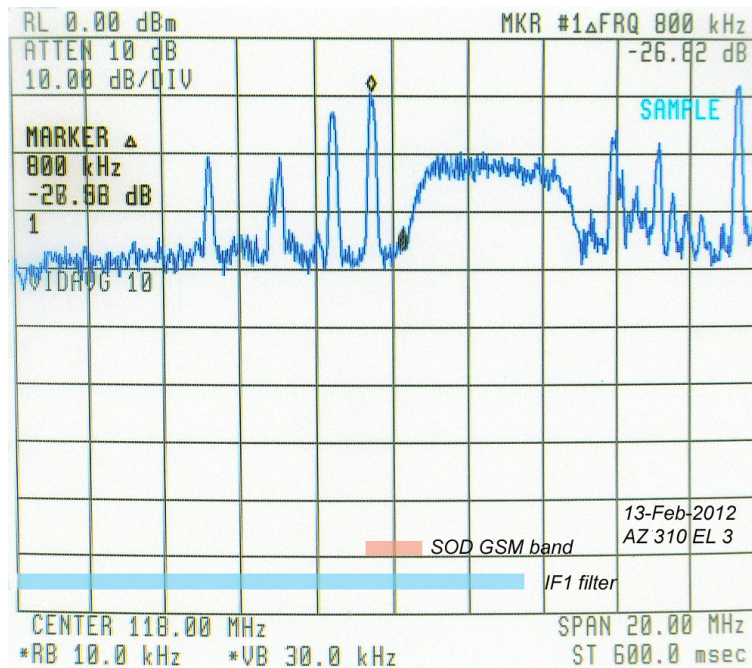

(a) IF1 without GSM filter (Y-path).

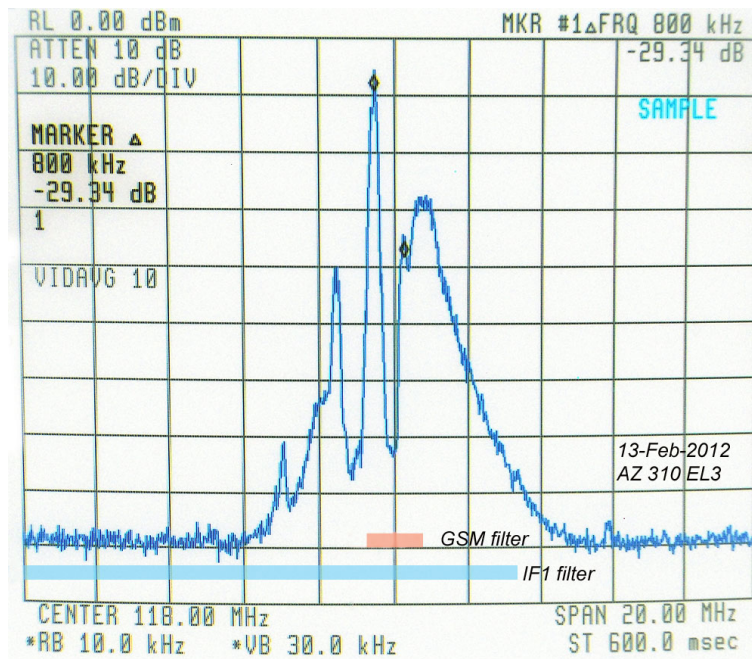

(b) IF1 with GSM filter (X-path).

Figure 26: **IF1 without and with the GSM filter.** Antenna was pointed to AZ 310°, EL 3°. Without the GSM filter, there is some 20–30 dB extra noise in the GSM’s filter passband, and probably elsewhere. Just removing a filter should not add noise into the filter’s passband in a linear system, so this must be a result of some kind of intermodulation picking unwanted stuff from somewhere.

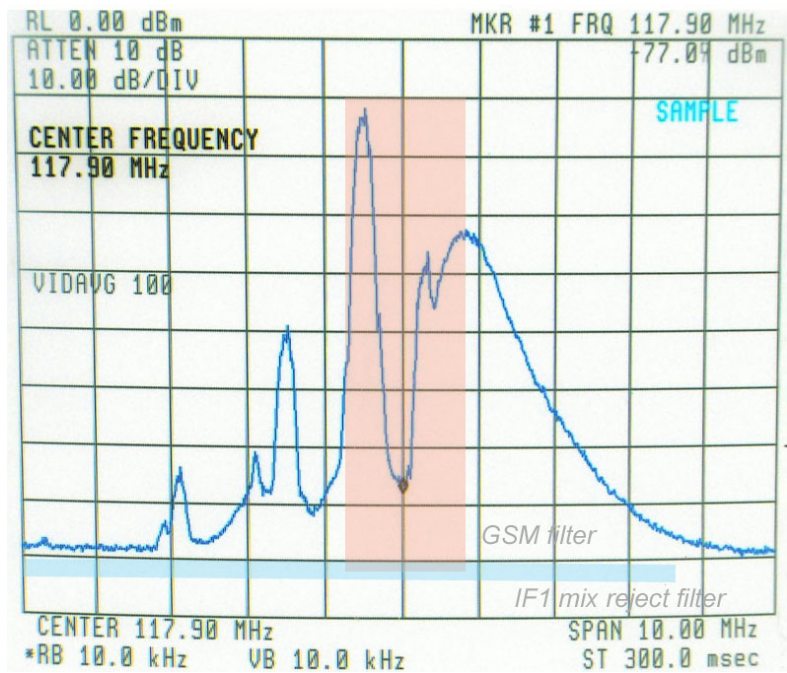

(a) IF1, at input of IF2 unit.

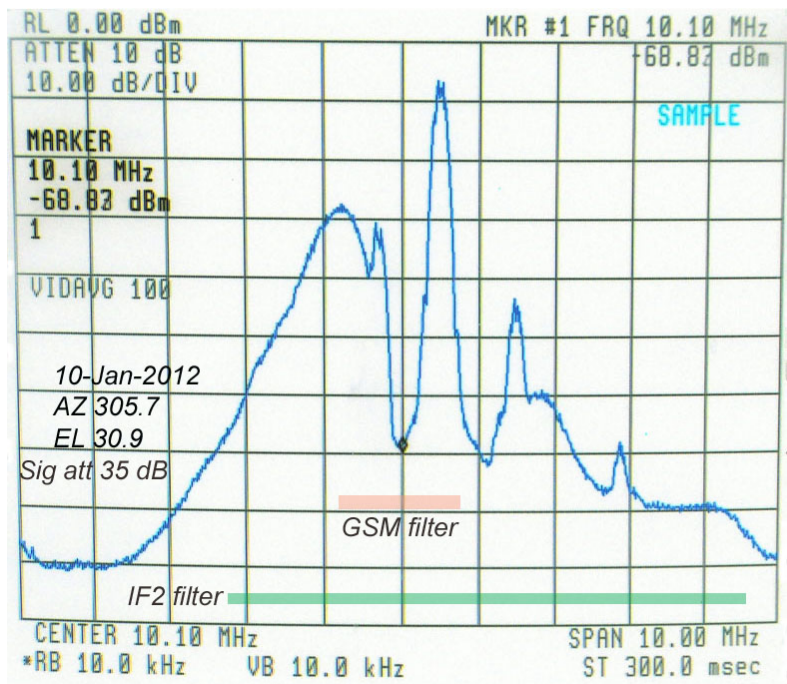

(b) Output of IF2 unit.

Figure 27: **IF2 v. IF1**. The antenna was pointed to AZ 305.7° EL 30.9°, the CP1 direction. Signal attenuation is 35 dB, required to keep IF2 output within ± 1 V for the A/D converter. With this much attenuation, the IF2 unit is well in the linear region.